



**Project Name:** East Area Water Control Facility  
**General Order No:** MAT0011132

**Negotiation No:** AT130311X0K1  
**Alternate No:** R003

Item No.	Qty	Product	Description
032	1	Dry Type Transformers	Transformer Type: Mini Power Centers 3 Phase, 15 KVA, 1 K-Factor 480 Primary Volts 208Y/120 Secondary Volts Temperature Rise 115C Copper Winding Material Sound Reduction : 0 NEMA ST-20 Audible Sound Level: 50 UL Listed : Y Enclosure Type: NEMA 4X Stainless Steel Operating Frequency: 60 HZ Stainless Steel (316) Enclosure
		<b>Catalog No</b>	P48G28T1524CUBS64X
		<b>Designation</b>	LVPC
	<b>Qty</b>	<b>List of Materials</b>	
	1		3 Phase, 15 KVA, 480 Primary Volts, 208Y/120 Secondary Volts, 115C Temperature Rise, Copper Winding Material, 60 HZ

Item No.	Qty	Product	Description
033	1	Safety Switches	Safety Switches
		<b>Catalog No</b>	DH366UWKN
		<b>Designation</b>	SS-HSDB
	<b>Qty</b>	<b>List of Materials</b>	
	1		Single Throw - Heavy Duty - Non-Fusible with Neutral, 3-Pole, 600 VAC, 600 A, NEMA 4X (304 Stainless)
	1		Neutral Assembly (Factory Installed)

Item No.	Qty	Product	Description
034	6	Safety Switches	Safety Switches
		<b>Catalog No</b>	DH361UWK
		<b>Designation</b>	SS-30/3/NF/N4X
	<b>Qty</b>	<b>List of Materials</b>	
	1		Heavy Duty Switch - Non-Fusible, 3-Pole, 600 VAC, 30 A, NEMA 4X (304 Stainless)

Item No.	Qty	Product	Description
035	14	HEAVY DUTY SAFETY SW	Safety Switch Access/Elec Interlock 30-800A 1NO-1N
		<b>Catalog No</b>	DS200EK1
	<b>Qty</b>	<b>List of Materials</b>	
	14		Safety Switch Access/Elec Interlock 30-800A 1NO-1N

**Project Name:** East Area Water Control Facility  
**General Order No:** MAT0011132

**Negotiation No:** AT130311X0K1  
**Alternate No:** R003

Item No.	Qty	Product	Description
036	6	HEAVY DUTY SAFETY SW	30A/3P HD NON-FUSIBLE SAFETY SWITCH 600V NEMA 4X S

**Catalog No** DH361UWK

**Qty** **List of Materials**  
6 30A/3P HD NON-FUSIBLE SAFETY SWITCH 600V NEMA 4X S

Item No.	Qty	Product	Description
037	8	HEAVY DUTY SAFETY SW	60A/3P HD Non-Fusible Safety Switch 600V Nema 4X S

**Catalog No** DH362UWK

**Qty** **List of Materials**  
8 60A/3P HD Non-Fusible Safety Switch 600V Nema 4X S

Item No.	Qty	Product	Description
038	1	Safety Switches	Safety Switches

**Catalog No** DH362UWK  
**Designation** 60A 4X

**Qty** **List of Materials**  
1 Heavy Duty Switch - Non-Fusible, 3-Pole, 600 VAC, 60 A, NEMA 4X (304 Stainless)

Item No.	Qty	Product	Description
039	7	MCCB SERIES C	TYPE GHB BREAKER 3P 20A 277/480VAC MAX 125/250VDC

**Catalog No** GHB3020  
**Designation** HSP

**Qty** **List of Materials**  
7 TYPE GHB BREAKER 3P 20A 277/480VAC MAX 125/250VDC

Item No.	Qty	Product	Description
040	1	MCCB SERIES C	TYPE GHB BREAKER 2P 20A 277/480VAC MAX 125/250VDC

**Catalog No** GHB2020  
**Designation** HSP

**Qty** **List of Materials**  
1 TYPE GHB BREAKER 2P 20A 277/480VAC MAX 125/250VDC

Item No.	Qty	Product	Description
041	1	MCCB SERIES C	TYPE GHB BREAKER 3P 40A 277/480VAC MAX 125/250VDC

**Catalog No** GHB3040  
**Designation** HSP

**EATON**

*Powering Business Worldwide*

**EATON**

*Powering Business Worldwide*

**EATON**

*Powering Business Worldwide*

**Project Name:** East Area Water Control Facility  
**General Order No:** MAT0011132

**Negotiation No:** AT130311X0K1  
**Alternate No:** R003

Item No.	Qty	Product	Description
033	1	Safety Switches	Safety Switches

**Catalog No** DH366UWKN  
**Designation** SS-HSDB

**Qty List of Materials**

- 1 Single Throw - Heavy Duty - Non-Fusible with Neutral, 3-Pole, 600 VAC, 600 A, NEMA 4X (304 Stainless)
- 1 Neutral Assembly (Factory Installed)

Item No.	Qty	Product	Description
034	6	Safety Switches	Safety Switches

**Catalog No** DH361UWK  
**Designation** SS-30/3/NF/N4X

**Qty List of Materials**

- 1 Heavy Duty Switch - Non-Fusible, 3-Pole, 600 VAC, 30 A, NEMA 4X (304 Stainless)

Item No.	Qty	Product	Description
035	14	HEAVY DUTY SAFETY SW	Safety Switch Access/Elec Interlock 30-800A 1NO-1N

**Catalog No** DS200EK1

**Qty List of Materials**

- 14 Safety Switch Access/Elec Interlock 30-800A 1NO-1N

Item No.	Qty	Product	Description
036	6	HEAVY DUTY SAFETY SW	30A/3P HD NON-FUSIBLE SAFETY SWITCH 600V NEMA 4X S

**Catalog No** DH361UWK

**Qty List of Materials**

- 6 30A/3P HD NON-FUSIBLE SAFETY SWITCH 600V NEMA 4X S

Item No.	Qty	Product	Description
037	8	HEAVY DUTY SAFETY SW	60A/3P HD Non-Fusible Safety Switch 600V Nema 4X S

**Catalog No** DH362UWK

**Qty List of Materials**

- 8 60A/3P HD Non-Fusible Safety Switch 600V Nema 4X S



# Detail Bill of Material

**Project Name:** East Area Water Control Facility  
**General Order No:** MAT0011132

**Negotiation No:** AT130311X0K1  
**Alternate No:** R003

Item No.	Qty	Product	Description
038	1	Safety Switches	Safety Switches
		<b>Catalog No</b>	DH362UWK
		<b>Designation</b>	60A 4X
	<b>Qty</b>	<b>List of Materials</b>	
	1	Heavy Duty Switch - Non-Fusible, 3-Pole, 600 VAC, 60 A, NEMA 4X (304 Stainless)	

Eaton Selling Policy 25-000 applies.

All orders must be released for manufacture within 90 days of date of order entry. If approval drawings are required, drawings must be returned approved for release within 60 days of mailing. If drawings are not returned accordingly, and/or if shipment is delayed for any reason, the price of the order will increase by 1.0% per month or fraction thereof for the time the shipment is delayed.

Seller shall not be responsible for any failure to perform, or delay in performance of, its obligations resulting from the COVID-19 pandemic or any future epidemic, and Buyer shall not be entitled to any damages resulting thereof.



**EATON**

*Powering Business Worldwide*

## Safety Switch General Information

### Global Specifications

System Voltage	600 VAC
Switch Type	Single Throw - Heavy Duty
Poles/Blades	3-Pole
Amperage	600
Protection	Non-Fusible with Neutral
Enclosure Type	NEMA 4X (304 Stainless)
Special Paint	No Paint
Fuse Clips	"H" Fuse Clips
Switch Lugs	(1) 2-600 & (1) 1/0-750
Fungus Proof Treatment	None
Lock-On Provision	None
Trapped Key Interlock	None
Upper Viewing Window	None
Fuse Pullers	None
Control Pole	None
Ground Lugs	(2) 6-250
Stainless Mechanism	None
Mill Duty	None

### Cover Controls

QUANTITY	DESCRIPTION
----------	-------------

### Nameplate

### Safety Switch Catalog No.

DH366UWKN

<p><b>The information on this document is created by Eaton Corporation. It is disclosed in confidence and it is only to be used for the purpose in which it is supplied.</b></p>	PREPARED BY	DATE	<b>Eaton</b>		
	NICHOLAS NATALE	2/16/2023			
	APPROVED BY	DATE	JOB NAME	East Area Water Control Facility	
			DESIGNATION	SS-HSDB	
	VERSION	TYPE		DRAWING TYPE	
	1.0.1.3	Safety Switch General Information		Customer Appr.	
NEG-ALT Number	REVISION	DWG SIZE	G.O.	ITEM	SHEET
AT130311X0K1-R003	0	A	MAT0011132	033	1 of 1



The Eaton logo consists of the word "EATON" in a bold, blue, sans-serif font. The letter "A" is stylized with a white triangle cutout. The letter "O" is a solid blue circle. The entire logo is centered at the top of the page.

*Powering Business Worldwide*

## Safety Switch General Information

### Global Specifications

System Voltage	600 VAC
Switch Type	Single Throw - Heavy Duty
Poles/Blades	3-Pole
Amperage	30
Protection	Non-Fusible with No Neutral
Enclosure Type	NEMA 4X (304 Stainless)
Special Paint	No Paint
Fuse Clips	"H" Fuse Clips
Switch Lugs	(1) 14-2
Receptacle Type	None
Fungus Proof Treatment	None
Lock-On Provision	None
Trapped Key Interlock	None
Upper Viewing Window	None
Fuse Pullers	None
Control Pole	None
Ground Lugs	(1) 14-4
Stainless Mechanism	None
Mill Duty	None

### Cover Controls

QUANTITY	DESCRIPTION
----------	-------------

### Nameplate

### Safety Switch Catalog No.

DH361UWK

<p><b>The information on this document is created by Eaton Corporation. It is disclosed in confidence and it is only to be used for the purpose in which it is supplied.</b></p>	PREPARED BY NICHOLAS NATALE	DATE 2/16/2023	<b>Eaton</b>		
	APPROVED BY	DATE	JOB NAME East Area Water Control Facility	DESIGNATION SS-30/3/NF/N4X	
	VERSION 1.0.1.3	TYPE Safety Switch General Information	DRAWING TYPE Customer Appr.		
NEG-ALT Number AT130311X0K1-R003	REVISION 0	DWG SIZE A	G.O. MAT0011132	ITEM 034	SHEET 1 of 1

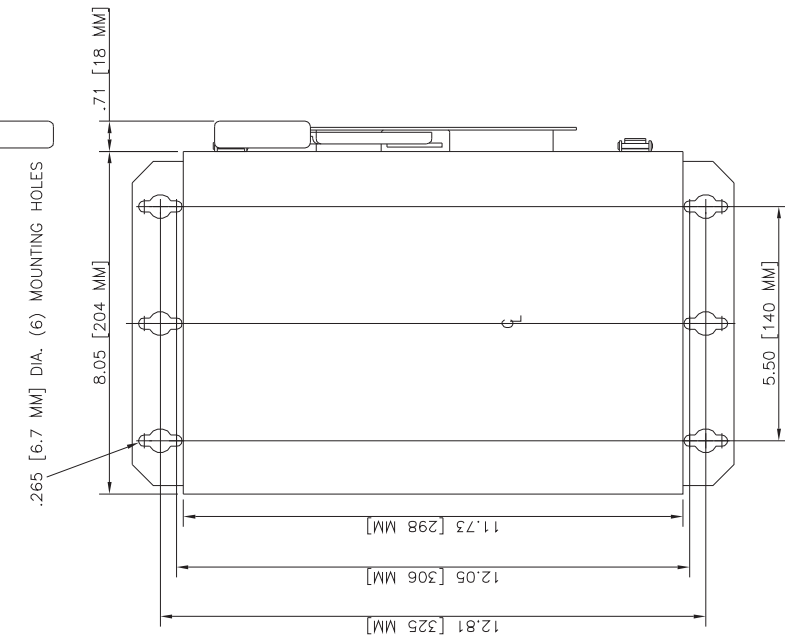
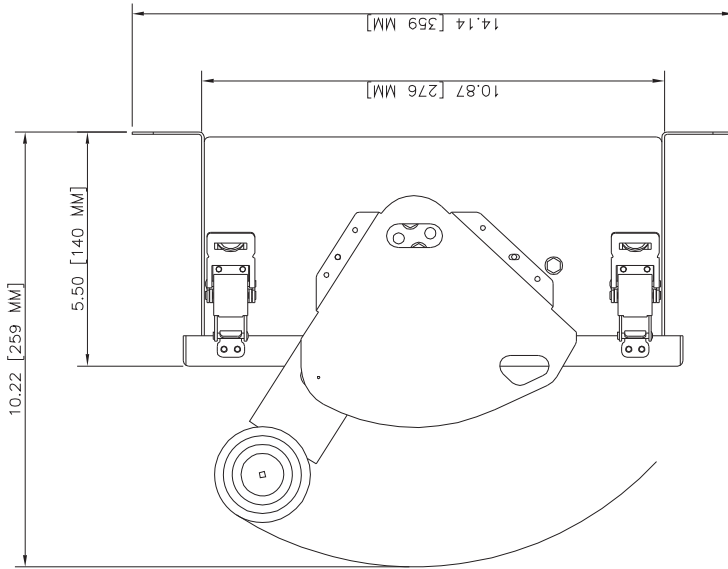
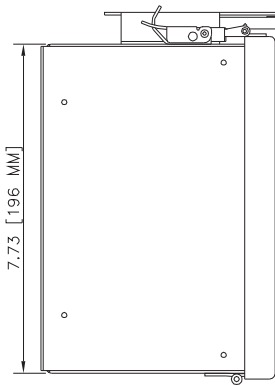

TITLE		DIMENSIONS FOR 30 AND 60 AMP 3 POLE NON-FUSIBLE TYPES 4X AND 12	
A	WS	RP	DP
B	MS	RP	DP
C	MS	RP	DP
DRAWN		CHECKED	
DATE		DATE	
BY		BY	
APP. F.		APP. F.	
FIRST ASSY.		FIRST ASSY.	
WHERE LISTED		WHERE LISTED	
Eaton		Eaton	
Cutler-Hammer		Cutler-Hammer	
95-1371		95-1371	



THE INFORMATION ON THIS DRAWING IS THE PROPERTY OF EATON CORPORATION, IS DISCLOSED IN CONFIDENCE, AND IS NOT TO BE REPRODUCED, USED, OR DISCLOSED EXCEPT FOR THE PURPOSE FOR WHICH IT IS FURNISHED.

C.2M REV. 10/21/94

GO/NEG-Alt-Date: MAT0011132-R003-2/16/2023		Job Name: East Area Water Control Facility
Item Number: 034	Catalog Number: DH361UWK	Designation: SS-30/3/NF/N4X

The Eaton logo consists of the word "EATON" in a bold, blue, sans-serif font. The letter "A" is stylized with a white triangle cutout, and the letter "O" is a solid blue circle.

*Powering Business Worldwide*

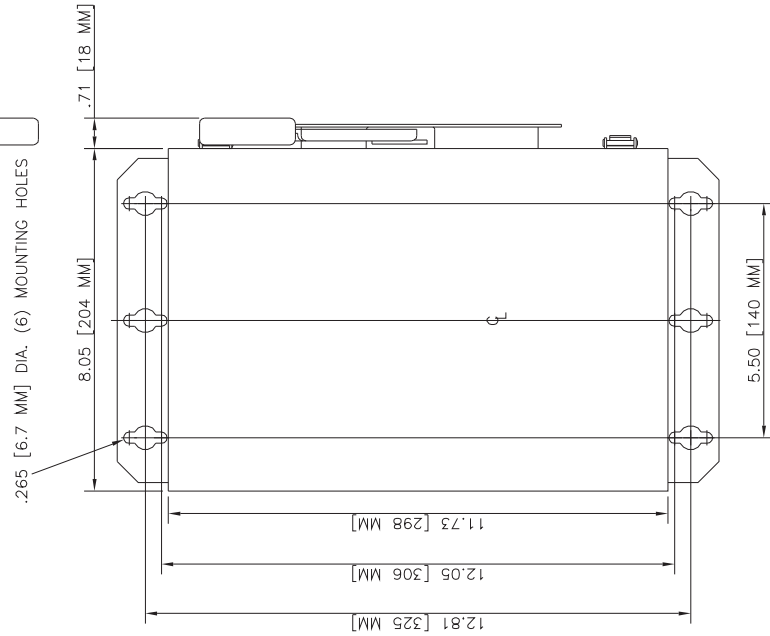
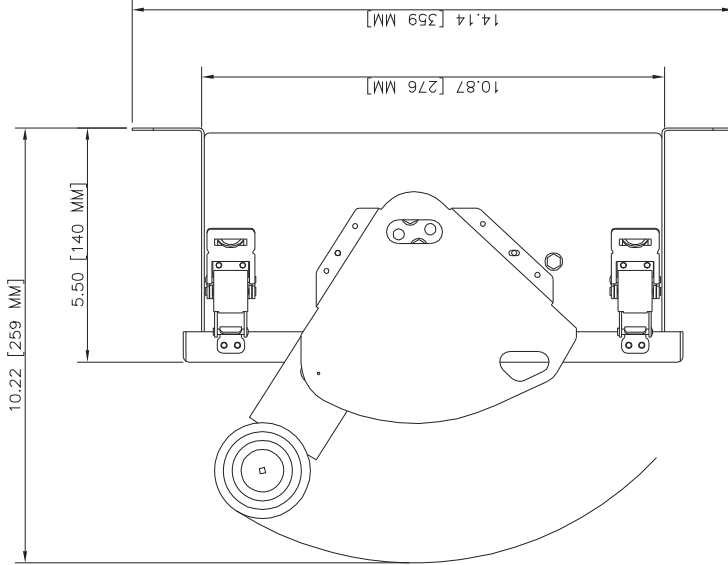
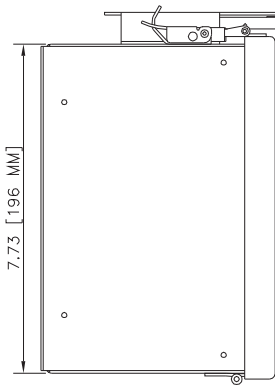

TITLE				DIMENSIONS FOR 30 AND 60 AMP 3 POLE NON-FUSIBLE TYPES 4X AND 12			
A	WS	RP	DS0331/1/10/1D	APP. F.	BUSCHOF	1/10/1	1/10/1
B				WARRANTY	ASSY.	WHERE LISTED	
C							

THIRD ANGLE PROJECTION

THE INFORMATION ON THIS DRAWING IS THE PROPERTY OF EATON CORPORATION, IS DISCLOSED IN CONFIDENCE, AND IS NOT TO BE REPRODUCED, USED, OR DISCLOSED EXCEPT FOR THE PURPOSE FOR WHICH IT IS FURNISHED.

**Eaton** Cutler-Hammer **C 95-1371**

C.S.M. REV. 10/21/94

FILE AT PTOC

GO/NEG-Alt-Date:  
MAT0011132-R003-2/16/2023

Job Name:  
East Area Water Control Facility

Item Number:  
036

Catalog Number:  
DH361UWK

Designation:



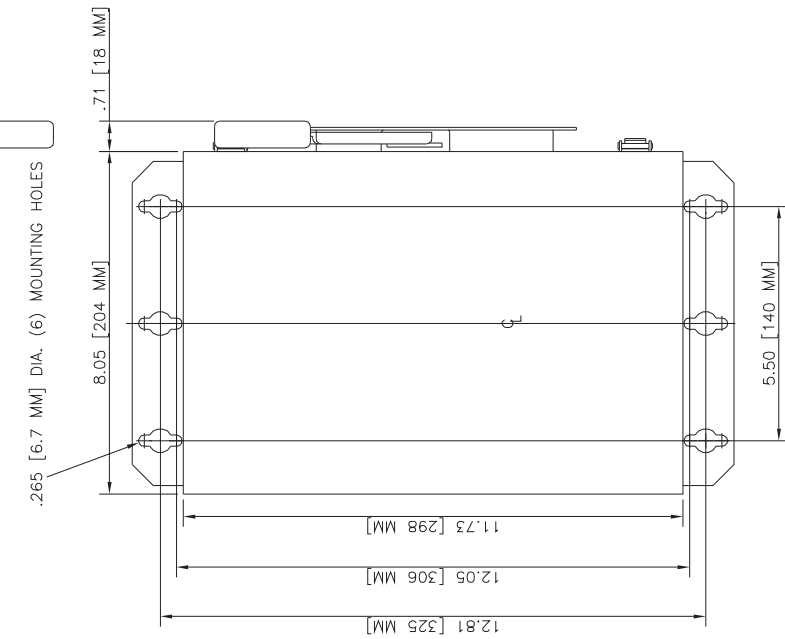
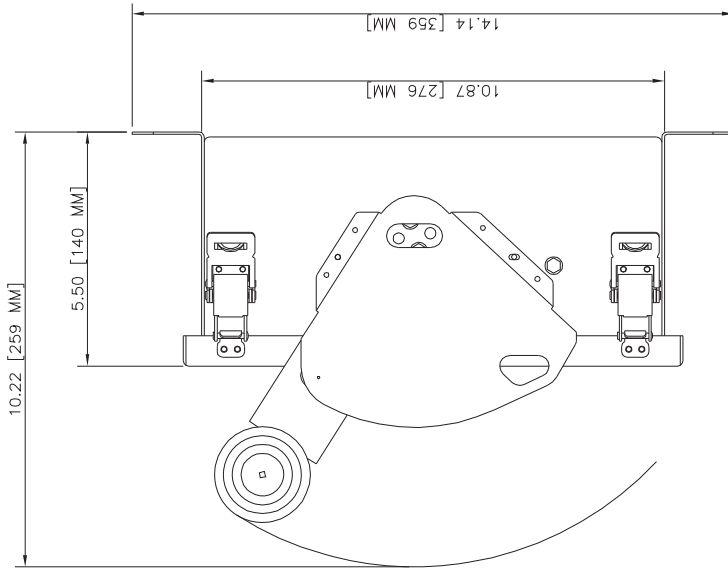
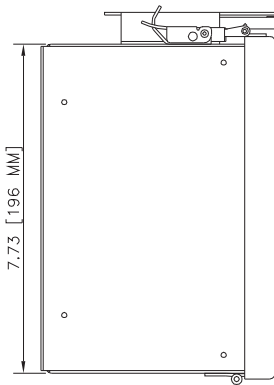

TITLE				DIMENSIONS FOR 30 AND 60 AMP 3 POLE NON-FUSIBLE TYPES 4X AND 12			
A	WS	RP	DS0331/1/10/1D	APP.	F.	BUSCHHOE	1/10/1D
B				BY	ARR	SIPE	1/10/1D
C				CHK.		FIRST ASSY.	WHERE LISTED

THIRD ANGLE PROJECTION

THE INFORMATION ON THIS DRAWING IS THE PROPERTY OF EATON CORPORATION, IS DISCLOSED IN CONFIDENCE, AND IS NOT TO BE REPRODUCED, USED, OR DISCLOSED EXCEPT FOR THE PURPOSE FOR WHICH IT IS FURNISHED.

**Eaton** Cutler-Hammer **95-1371**

C.2M REV. 10/21/94

FILE AT PTOC

GO/NEG-Alt-Date: MAT0011132-R003-2/16/2023		Job Name: East Area Water Control Facility
Item Number: 037	Catalog Number: DH362UWK	Designation:

## Safety Switch General Information

### Global Specifications

System Voltage	600 VAC
Switch Type	Single Throw - Heavy Duty
Poles/Blades	3-Pole
Amperage	60
Protection	Non-Fusible with No Neutral
Enclosure Type	NEMA 4X (304 Stainless)
Special Paint	No Paint
Fuse Clips	"H" Fuse Clips
Switch Lugs	(1) 14-2
Receptacle Type	None
Fungus Proof Treatment	None
Lock-On Provision	None
Trapped Key Interlock	None
Upper Viewing Window	None
Fuse Pullers	None
Control Pole	None
Ground Lugs	(1) 14-4
Stainless Mechanism	None
Mill Duty	None

### Cover Controls

QUANTITY	DESCRIPTION
----------	-------------

### Nameplate

### Safety Switch Catalog No.

DH362UWK

<p><b>The information on this document is created by Eaton Corporation. It is disclosed in confidence and it is only to be used for the purpose in which it is supplied.</b></p>	PREPARED BY NICHOLAS NATALE	DATE 2/16/2023	<b>Eaton</b>		
	APPROVED BY	DATE	JOB NAME East Area Water Control Facility	DESIGNATION 60A 4X	
	VERSION 1.0.1.3	TYPE Safety Switch General Information	DRAWING TYPE Customer Appr.		
NEG-ALT Number AT130311X0K1-R003	REVISION 0	DWG SIZE A	G.O. MAT0011132	ITEM 038	SHEET 1 of 1

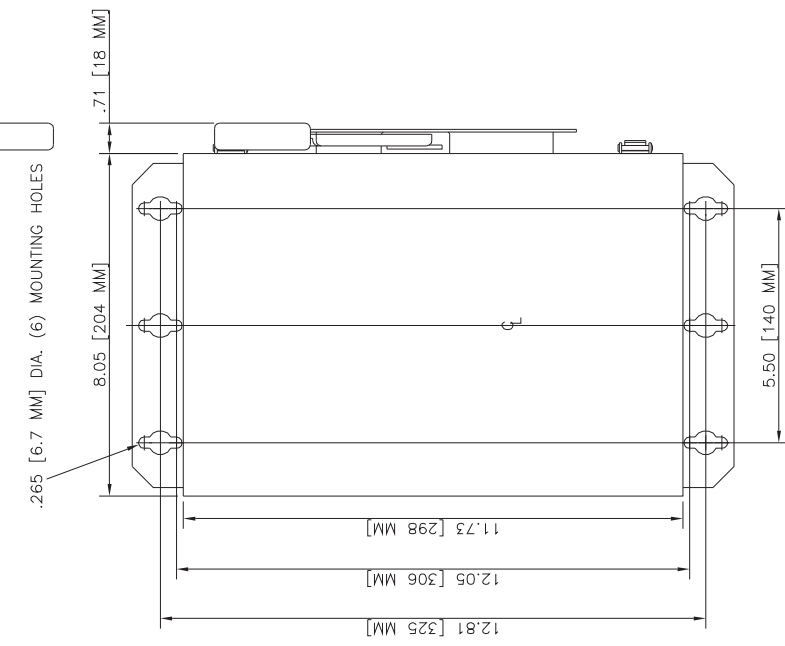
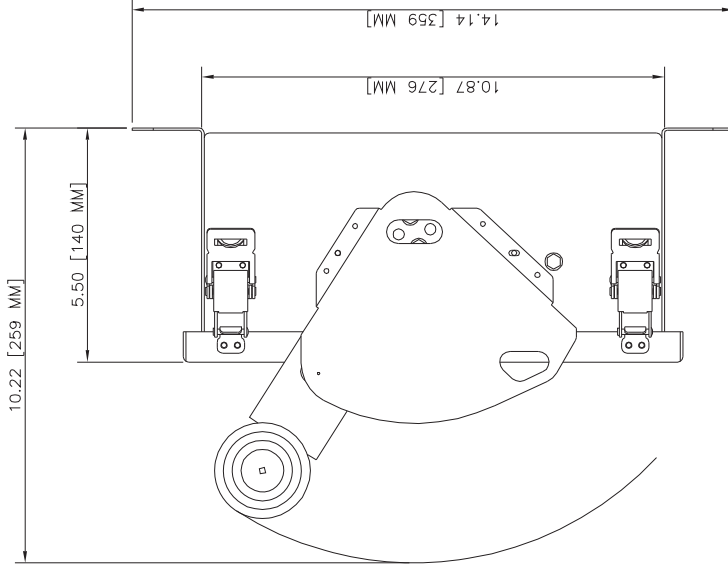
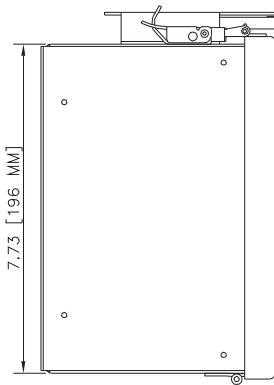

.265 [6.7 MM] DIA. (6) MOUNTING HOLES

TITLE		DIMENSIONS FOR 30 AND 60 AMP 3 POLE NON-FUSIBLE TYPES 4X AND 12	
A	WS	RP	DP
B	MS	RP	DP
C	MS	RP	DP
DRAWN		CHECKED	
DATE		DATE	
BY		BY	
APP. F.		APP. F.	
FIRST ASSY.		FIRST ASSY.	
WHERE LISTED		WHERE LISTED	
Eaton		Eaton	
Cutler-Hammer		Cutler-Hammer	
95-1371		95-1371	



THE INFORMATION ON THIS DRAWING IS THE PROPERTY OF EATON CORPORATION, IS DISCLOSED IN CONFIDENCE, AND IS NOT TO BE REPRODUCED, USED, OR DISCLOSED EXCEPT FOR THE PURPOSE FOR WHICH IT IS FURNISHED.

GO/NEG-Alt-Date: MAT0011132-R003-2/16/2023		Job Name: East Area Water Control Facility
Item Number: 038	Catalog Number: DH362UWK	Designation: 60A 4X

**EATON**

*Powering Business Worldwide*

Low-voltage power distribution and control systems > Switches and disconnects >

# Safety switches

## Contents

<b>General Description</b> . . . . .	<b>28.1-2</b>
Product Description . . . . .	28.1-2
Safety Switch Selection Guide . . . . .	28.1-3
General-Duty . . . . .	28.1-4
Heavy-Duty . . . . .	28.1-4
Enhanced Visible Blade . . . . .	28.1-4
Window Switches . . . . .	28.1-5
Heavy-Duty Surge Switch . . . . .	28.1-5
EnviroLine . . . . .	28.1-5
Heavy-Duty Double-Throw . . . . .	28.1-6
Shunt Trip Safety Switch . . . . .	28.1-7
Auxiliary Power Heavy-Duty Safety Switch . . . . .	28.1-7
Enclosed Rotary . . . . .	28.1-7
<b>Accessories</b> . . . . .	<b>28.1-8</b>
Accessories and Field Kits . . . . .	28.1-8
<b>Flex Center Offerings</b> . . . . .	<b>28.1-10</b>
Flex Center . . . . .	28.1-10
<b>Layouts and Dimensions</b> . . . . .	<b>28.1-11</b>
General-Duty . . . . .	28.1-11
Heavy-Duty . . . . .	28.1-12
Heavy-Duty Safety Switches with Surge Protection . . . . .	28.1-13
EnviroLine . . . . .	28.1-14
Heavy-Duty Double-Throw . . . . .	28.1-16
Shunt Trip . . . . .	28.1-17
Auxiliary Power Heavy-Duty Safety Switch . . . . .	28.1-17
Enclosed Rotary . . . . .	28.1-18
<b>Application Details</b> . . . . .	<b>28.1-23</b>
Maximum Horsepower Ratings . . . . .	28.1-23
Short-Circuit Ratings . . . . .	28.1-25
Fuse Dimensions . . . . .	28.1-26
<b>Catalog Numbering Systems</b> . . . . .	<b>28.1-28</b>



**Note:** For customized safety switches see, Safety Switches—Customized Solutions (CA008014EN).

# EATON

Powering Business Worldwide



More about this product  
[Eaton.com/switches](https://www.eaton.com/switches)



Complete library of design guides  
[Eaton.com/designguides](https://www.eaton.com/designguides)

Product Description

Safety Switches

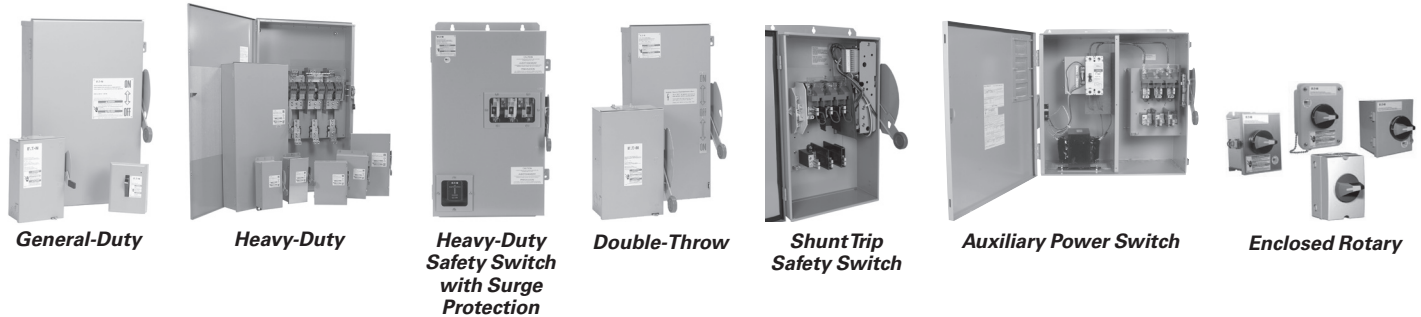

Safety switches have a number of applications from service entrance to branch circuit protection. They are also horsepower rated for use as motor circuit switches. **Table 28.1-1** summarizes major differences and similarities between the heavy-duty and general-duty type of Eaton’s safety switches. In addition to heavy-duty and general-duty applications, we have seen many industry trends that have created needs for specialized versions of safety switches:

- Eaton’s EnviroLine line of switches come with options for stainless steel enclosures, mechanisms and springs, various types of interlocked receptacles, viewing windows and also non-metallic enclosures for use in abnormal environments. Solar switches made to meet specific requirements and demands of the solar industry

- Shunt trippable switches for a quick and safe means to remotely open a switch in an emergency situation. Service Entrance capability at 480 Vac, 1200 A with integrated ground fault relay and/or arc reduction relay
- Auxiliary power switches for providing control power for HVAC and other applications that may require disconnect and receptacle to meet NEC requirements
- Rotary switches for OEM and compact applications where space is limited

If you don’t see your specific application listed above, make sure to call your local Eaton salesperson to discuss the capabilities of our Flex Center that will provide custom switches to meet many industry needs.

The following pages give more details on the many types of switching devices Eaton can provide to meet your every need.

Table 28.1-1. Safety Switch Application Guide—See Catalog Selection Tables for Specific Ratings

Application/ Features	General-Duty Safety Switches	Heavy-Duty Safety Switches
Type of facility	Residential, commercial, light industrial	Commercial, institutional, industrial
Maximum voltages	240 Vac—250 Vdc in larger sizes	600 Vac—250 Vdc and 600 Vdc
Short-circuit rating for non-fused switches	10,000 rms symmetrical amperes	10,000 rms symmetrical amperes. Higher combination ratings available with upstream Eaton molded case circuit breakers and fuses.
Short-circuit rating with standard fuse clips	With Class H fuse clips—10,000 rms symmetrical amperes	Switches with Class H Fuse Clips—10,000 rms amperes 800–1200 A switches with Class L fusing—200,000 rms
Short-circuit rating with fuse options	Class R fuse adaptation and 400–600 A switches with T or J fuse adaptation—100,000 rms amperes	Switches with Class R or Class J fusing and 200–800 A switches with Class T fuse adaptation—200,000 A at 480 V and 100,000 rms symmetrical amperes at 600V
Ampere sizes	30, 60, 100, 200, 400, 600	30, 60, 100, 200, 400, 600, 800, 1200
Maximum horsepower ratings	200 hp at 240 Vac	250 hp at 240 V, 500 hp at 480 and 600 Vac
UL (NEMA) enclosure types	Type 1—general purpose indoor use Type 3R—rainproof and sleet-resistant	Type 1 indoor, 3R outdoor Type 4 watertight and dust-tight Type 4X watertight, dust-tight and corrosion-resistant Type 12 indoor falling dust, dirt and liquids Type 12/3R convertible to outdoor use Type 7/9 hazardous (classified) locations
Terminals	Box lug (screw pressure) for Al/Cu wire	Box lug (screw pressure) for Al/Cu wire
Electrical interlock—snap-switch type	Field-installed kit, 200–600 A sizes	Field- or factory-installed for all sizes
Control pole interlock	Field-installed kit, 400–600 A sizes	Field- or factory-installed for K-Series switches
Fuse pullers	Not available	Standard in Type 4X and 12 enclosed switches through 200 A field- or factory-installed for all other 30–200 A switches

## Safety Switch Selection Guide

Table 28.1-2. Safety Switch Selection Guide

Type	Fuse Type	Fuse Class	Ampere Rating	Number of Poles	Enclosure Types									
					NEMA 1	NEMA 3R	NEMA 12	NEMA 4 Painted Steel	NEMA 4X Stainless Steel	NEMA 4X Non-Metallic	NEMA 4X 316 Grade Stainless Steel	NEMA 7/9		
General-duty	Single-throw max. 240 Vac horsepower rated	Fusible	Plug	—	30	1 and 2	Yes	Yes	—	—	—	—	—	—
		Cartridge	H ①	30–600	2 and 3	Yes	Yes	—	—	—	—	—	—	
		Non-fusible	—	—	30–600	2 and 3	Yes	Yes	—	—	—	—	—	
Heavy-duty ②	Single-throw max. 600 Vac horsepower rated	Fusible	Cartridge	H ① L	30–600 800–1200	2, 3 and 4	Yes up to 1200 A	Yes up to 1200 A	Yes ③ up to 1200 A	Yes 400–1200 A	Yes up to 1200 A	Yes up to 200 A	Yes up to 1200 A	Yes ④ up to 100 A
		Non-fusible	—	—	30–1200	2, 3 and 4	Yes	Yes	Yes ③ up to 1200 A	Yes 400–1200 A	Yes up to 1200 A	Yes up to 200 A	Yes up to 1200 A	Yes up to 100 A
Double-throw	Max. 600 Vac horsepower rated	Fusible	Cartridge	H ① T (600V) J L	30–400 400 600 800–1200	2 and 3	Yes	Yes	Yes up to 600 A ③	—	Yes up to 400 A	—	Yes up to 400 A	—
		Non-fusible	—	—	30–1200	2, 3, 4 and 6	Yes	Yes	Yes up to 800 A ③	—	Yes up to 600 A	—	Yes up to 600 A	—
Shunt trip	Single-throw max. 600 Vac horsepower rated	Fusible	Cartridge	H ① L	30–600 800–1200	2, 3 and 4	—	—	Yes ③	Yes	Yes	—	Yes	—
		Non-fusible	—	—	30–1200	2, 3 and 4	—	—	Yes ③	Yes	Yes	—	Yes	—
Auxiliary power heavy-duty	Max. 600 Vac horsepower rated	Fusible	Cartridge	H ①	30–200	3	—	Yes	—	—	—	—	—	—
		Non-fusible	—	—	30–200	3	—	Yes	—	—	—	—	—	—
Rotary switches	Max. 600 Vac	Non-fusible	—	—	16–80	3, 4	Yes	Yes	Yes	—	Yes	Yes	Yes	—

① Class J, R and T available in many instances with the use of adapter kits listed on Page 28.1-8.

② Data applicable to heavy-duty, enhanced visible blade and heavy-duty surge switches.

③ NEMA Type 12 enclosures (30–1200 A) can be field modified to meet NEMA 3R rainproof requirements when a factory provided drain screw is removed.

④ Class J clips provided.

Table 28.1-3. EnviroLine Safety Switch Selection Guide

EnviroLine	Fuse Type	Fuse Class	Ampere Rating	Number of Poles	Enclosure Types						
					NEMA 1	NEMA 3R	NEMA 12	NEMA 4 Painted Steel	NEMA 4X Stainless Steel	NEMA 4X Non-Metallic	
Stainless enclosure with stainless mechanism	Fusible	Cartridge	H ⑤	30–400	2 and 3	—	—	—	—	Yes	—
	Non-fusible	—	—	30–400	3	—	—	—	—	Yes	—
Viewing window	Fusible	Cartridge	H ⑤ L	30–600 800–1200	2, 3, 4 and 6	—	—	Yes ⑥	Yes	Yes	—
	Non-fusible	—	—	30–1200	2, 3, 4 and 6	—	—	Yes ⑥	Yes	Yes	—
Welding receptacle	Fusible	Cartridge	H ⑤	30–100	3	—	—	Yes ⑥	—	Yes	—
	Non-fusible	—	—	30–100	3	—	—	Yes ⑥	—	Yes	—
Non-metallic	Fusible	Cartridge	H ⑤	30–200	3	—	—	—	—	—	Yes
	Non-fusible	—	—	30–200	3	—	—	—	—	—	Yes

⑤ Class J, R and T available in many instances with the use of adapter kits listed on Page 28.1-8.

⑥ NEMA Type 12 enclosures (30–1200 A) can be field modified to meet NEMA 3R rainproof requirements when a factory provided drain screw is removed.

## General-Duty



**General-Duty (Plug Fuse)**



**General-Duty (Cartridge Fuse)**

For residential and commercial applications. Suitable for light-duty motor circuits and service entrance.

- 240 Vac
- 30–600 A
- For short-circuit ratings, see **Table 28.1-42**
- Suitable for service entrance applications unless otherwise noted
- Fusible and non-fusible switches are 100% load break and load make rated
- The continuous load current of fusible switches is not to exceed 80% of the rating of fuses employed in other than motor circuits. Non-fusible switches are 100% fully rated
- 200–600 A features K-Series design
- Horsepower rated
- Ample wire bending space provides for easier installation
- With Class R fuses, switches may be used on systems capable of delivering 100,000 A rms symmetrical

**Note:** Plug fuse switches are not service entrance rated.

## Heavy-Duty

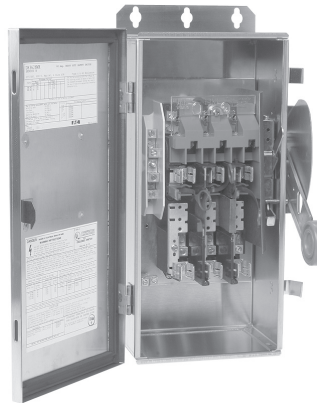

**Heavy-Duty**

For heavy-duty commercial and industrial applications where reliable performance and service continuity are critical.

- 600 Vac, 600 Vdc maximum
- 30–1200 A
- For short-circuit ratings, see **Table 28.1-43**
- Horsepower rated
- Fusible and non-fusible switches are 100% load break and load make rated
- The continuous load current of fusible switches is not to exceed 80% of the rating of fuses employed in other than motor circuits. Non-fusible switches are 100% fully rated
- Suitable for service entrance applications unless otherwise noted
- Visible double break rotary blade mechanism. Two points of contact provide a positive open and close, easier operation, and also help to prevent contact burning for longer contact life
- Triple padlocking capability. Personnel safety feature because the large hasp can accommodate up to three 3/8-inch (9.5 mm) shank locks. Cabinet door can be further padlocked at the top and bottom
- Interlocking mechanism. Door cannot be opened when the handle is in the ON position. Built-in defeater mechanism provides for user access when necessary
- De-ionizing arc chutes. Arc chutes confine and suppress the arcs produced by contacts under load

## Enhanced Visible Blade

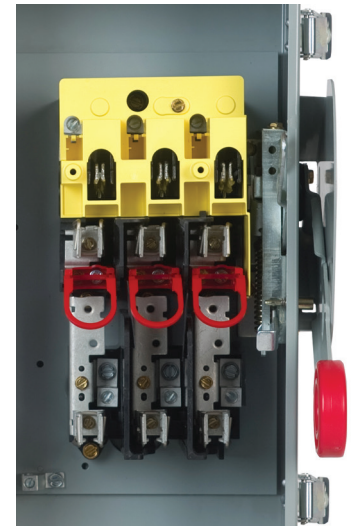

**Enhanced Visible Blade**

- Heavy-duty safety switches with enhanced visible blade provide a highly visible means of disconnect to help improve personnel safety and equipment protection
- Enhanced visible means of disconnect allows personnel to clearly see that blades are disengaged from stationary contacts when the switch handle is in the OFF position
- New visible blade design provides increased visibility over each pole, allowing users to clearly see the trailing edge of the blade
- Material color update from red to yellow creates greater contrast between blades and arc shield
- Available in 30–1200 A ratings
- Fusible and non-fusible configurations in two-, three-, four- and six-pole
- NEMA 1, 3R, 12, 4 and 4X enclosures for robust environmental protection
- Modifications available such as auxiliary contacts, pilot lights and more. Call the Flex Center at 888-329-9272 or email [FlexSwitches@eaton.com](mailto:FlexSwitches@eaton.com)
- To order safety switches with enhanced visible blade features and no viewing window, the standard heavy-duty catalog number should be used with the addition of a 'V' suffix



## Window Switches



**Advanced Visibility Features**

These switches incorporate a new external viewing window to replace the internal design. The new design instills confidence by allowing users to easily view the trailing edge of the blade to confirm disconnect is open while the switch handle is in the OFF position.

- All Eaton safety switches featuring a viewing window incorporates enhanced visible blade components as standard
- Viewing window provides clear path to view switch interior
- Window material is high-quality laminated safety glass
- External viewing window design is field replaceable—kits available for switches 30–1200 A
- 30 A and 60 A heavy-duty safety switches feature a vertical viewing window
- 100–1200 A heavy-duty safety switches feature a horizontal viewing window(s)
- Ratings are 30–1200 A, 240–600 Vac, fusible and non-fusible. Available in NEMA 12/3R, 4X stainless steel enclosures

## Heavy-Duty Surge Switch



**Heavy-Duty Surge Switch**

Eaton's Switching Device product line combined heavy-duty safety switches and Eaton's SP1 and CVX series surge protective devices (SPDs) to provide reliable, cost-effective surge protection. Integral to the switch, an SPD provides significantly better performance compared to a device that is externally mounted, resulting in better protection for connected equipment. Eaton's new packaged solution provides contractors and end users a UL listed product by connecting the SPD to the safety switch at the factory.

- 30–1200 A
- NEMA 12/3R or 4X 304-grade stainless steel enclosures
- External window over switching base standard
- Window to view LEDs of SPD for quick status view
- Enhanced visible blades included
- Eaton Type SP1 and CVX surge protective devices available

## EnviroLine



**Stainless Steel Switch**

Eaton offers a line of safety switches designed for your special application and/or extreme environmental conditions.

The EnviroLine stainless steel switch is primarily used in the meatpacking and food processing industries, or any application where water is frequently used to hose down equipment.

- Stainless steel NEMA 4X enclosure
- Stainless steel interior mechanism, back pan and springs
- Available in 30–400 A ratings, 240–600 Vac
- Fusible and non-fusible configurations
- 316 grade stainless steel option replaces standard 304 grade stainless steel and hardware with 316 stainless. 316 stainless holds up better in high salt environments found in coastal areas, and in water/wastewater applications

## EnviroLine

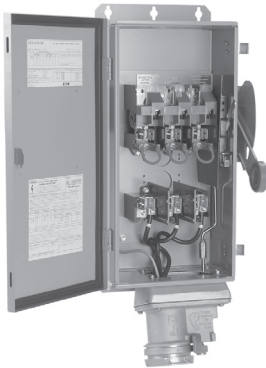

*Receptacle Switches*

### Receptacle Switches

These heavy-duty switches are pre-wired and interlocked to polarized receptacles for three-phase, three-wire, grounded type power plugs.

- Used for portable power applications such as welders, infrared ovens, batch feeders, conveyors, and truck and marine docks
- Receptacles are interlocked to handle mechanisms so that power plugs may not be inserted or removed when the switch is in the ON position unless noted otherwise
- Ratings are 30–100 A, 600 Vac
- Available in NEMA 12 and 4X stainless steel enclosures



*Non-Metallic Switches*

### Non-Metallic Switch

This switch has a KRYDON™ enclosure. This is a compression molded fiberglass reinforced polyester enclosure, which is capable of withstanding almost any corrosive environment. Ratings are 30–200 A, 240–600 Vac, fusible and non-fusible. Enclosure is NEMA 4X rated.

## Heavy-Duty Double-Throw

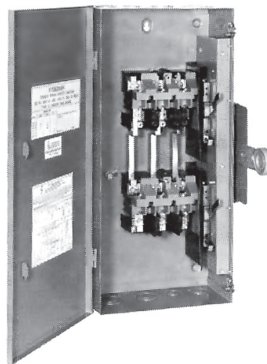

*Heavy-Duty Double-Throw*

Used to transfer service from a normal power source to an alternate source, or to switch from one load circuit to another.

- For short-circuit ratings, see **Table 28.1-44**
- 30–1200 A switches are horsepower rated
- 600 Vac, 250 Vdc maximum
- Fusible or non-fusible
- Fusible and non-fusible switches are 100% load break and load make rated
- The continuous load current of fusible switches is not to exceed 80% of the rating of fuses employed in other than motor circuits. Non-fusible switches are 100% fully rated
- Suitable for service entrance applications unless otherwise noted
- Wiring configuration from factory allows a single load to be supplied by a normal or alternate source. Can be field modified to allow two loads to be alternately supplied by a single source
- Ample wire bending space provides for easier installation
- Visible double-break rotary blade mechanism. Two points of contact provide a positive open and close, easier operation, and also help to prevent contact burning for longer contact life

- Triple padlocking capability. Personnel safety feature because the large hasp can accommodate up to three 3/8-inch (9.5 mm) shank locks
- Clearly visible handle. The position (ON or OFF) can be clearly seen from a distance
- Additional locking capability. Cabinet door can be further padlocked at the top and bottom
- Clear line shield protects against accidental contact with energized parts. Probe holes enable the user to test if the line side is energized without removing the shield
- De-ionizing arc chutes. Arc chutes confine and suppress the arcs produced by contacts under load
- UL listed switching neutral capability is available on three-pole and four-pole non-fusible double-throw switches with the installation of the proper bonding kit shown on **Page 28.1-3**
- 600–1200 A fusible utilizes a common set of fuses; two source, one load applications

### Shunt Trip Safety Switch

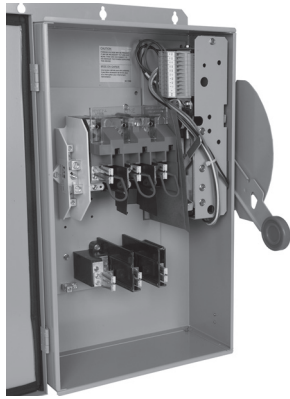

*Shunt Trip Safety Switch*

Integrates shunt trip technology, enhancing safety by providing a means to remotely open a safety switch electrically.

- Heavy-duty safety switch design with integrated shunt trip module
- Visible means of disconnect—visible blade
- 30–800 A (240–600 Vac)
- NEMA® Type 12/3R, 4 (painted steel) and 4X (stainless steel) enclosures
- Horsepower ratings same as standard safety switches
- Passes Class 1 ground fault testing (1200% opening)
- Maximum response time of 50 ms
- Switch arcing time less than 10 ms (AC)
- Class H fuse clips supplied as standard on fusible devices 30–600 A, Class L for 800 A; Class R, J, T fuse clips available

Modifications available, such as viewing windows, pilot lights, and more. Call the Flex Center at 888-329-9272 for more information.

### Auxiliary Power Heavy-Duty Safety Switch

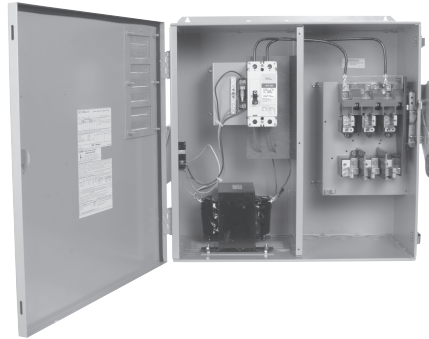

*Auxiliary Power Heavy-Duty Safety Switch*

NEC Article 210.63 requires that a 125 V, single-phase, 15 or 20 A rated receptacle be installed at an accessible location for the servicing of heating, air-conditioning and refrigeration equipment. The receptacle must be located on the same level and within 25 ft (7.5 m) of the heating, air-conditioning and refrigeration equipment. Eaton's heavy-duty safety switch is an ideal solution for these applications, including elimination of the need for running a separate 120V circuit to the rooftop.

- 30–200 A
- Horsepower rated
- NEMA 3R outdoor enclosure standard
- 15 A ground fault receptacle standard

### Enclosed Rotary



*Enclosed Rotary*







Provides users with the ability to lock directly wired motor loads in the OFF position to comply with new OSHA lockout/tagout regulations. Also for machine applications that require compact, economical disconnect switches.





- Padlockable in the OFF position (up to three padlocks) to meet OSHA lockout requirements
- Available 16–80 A ratings
- 600 Vac, three- and four-pole non-fusible device
- Rated at highest available hp rating (at 480 Vac, 16 A–10 hp, 25 A–15 hp, 30 A–15 hp, 40 A–20 hp, 60 A–30 hp, 80 A–40 hp)
- Rated for making and breaking loads
- Accepts auxiliary contacts
- Capability to signal PLC controllers
- Ground lug connection provided
- Can be rated up to 65 kAIC, when protected by applicable upstream fusing

## Accessories and Field Kits

### For General Duty, Heavy Duty and Double Throw Safety Switches

Table 28.1-4. Safety Switches—Accessories

Description	Catalog Number	
<b>Neutral Kits ①</b>		
	<b>DH030NK</b>	
	30 A DG	DG030NB
	60–100 A DG	DG100NB
	200 A DG, DH (NEMA 1, 3R enclosures)	DG200NK
	30–60 A DH	DH030NK
	100 A DH	DH100NK
	200 A DH (NEMA 4X, 12 enclosures)	DH200NK
	400 A DG, DH	DS400NK
	600 A DG, DH	DS600NK
	400 A fusible DT, 800–1200 A DH	DS800NK
	30–100 A DT	DT100NK
	200 A DT	DT200NK
	400 A non-fusible DT	DT400NK
	600 A non-fusible DT	DT600NK
600 A fusible DT, 800 A DT	DT800NK	
1200 A DT	DT1200NK	
<b>Ground Lug Kits</b>		
Factory-installed ground lug is supplied in all safety switches		
	<b>DS200GK</b>	
	30–100 A DG	DG030GB
	30–100 A DH, DT ②	DS100GK
	200 A DG, DH, DT	DS200GK
400–600 A DG, 400–1200 A DH, 400–1200 A DT	DS468GK	
<b>Switching Neutral Bonding Kits ③</b>		
	<b>DT100BK</b>	
	30–100 A DT, 3P, 4P non-fusible	DT100BK
	200 A DT, 3P, 4P non-fusible	DT200BK
	400 A DT, 3P, 4P non-fusible	DT400BK
	600 A DT, 3P, 4P non-fusible	DT600BK
800–1200 A DT, 3P, 4P non-fusible	DT800BK	
<b>Control Pole Kit (For 2P, 3P Switches)</b>		
	<b>DS16CP</b>	
	400–600 A DG, 30–1200 A DH, 30–1200 A DT Multiple key options are included with the control pole kit. Standard keys provide late-make, early-break functionality. Flanged key provides same make, same break functionality.	DS16CP
<b>Auxiliary Contact Kits</b>		
Auxiliary contact kits are not field installable on shunt trip safety switches		
	<b>DS200EK1</b>	
	All switches (except 30–100 A DG) 1NO/1NC	DS200EK1 ④
	All switches (except 30–100 A DG) 2NO/2NC	DS200EK2 ④
	NEMA 7/9 switches (30–100 A) 1NO/1NC	178C265G05
NEMA 7/9 switches (30–100 A) 2NO/2NC	178C265G06	
<b>Copper Lug Kits</b>		
	<b>DS36CL</b>	
	30 A DH, DT ⑤	DS16CL
	60 A DH, DT ⑤	DS26CL
	100 A DH, DT ⑤	DS36CL
	200 A DH ⑤	DS46CL
	400 A DH (NEMA 4, 4X, 12 enclosures) ⑤	DS56CL
600–800 A DH (NEMA 4, 4X, 12 enclosures) ⑤	DS66CL	

Description	Catalog Number	
<b>Crimp Lug Pad Kit (NEMA 4, 4X, 12 Enclosures Only)</b>		
	<b>DS56CK</b>	
	400–600 A DH ⑤	DS56CK
	800 A DH ⑤	DS76CK
400–800 A neutral DH ⑤	DS800CNK	
<b>Fuse Puller Kits</b>		
	<b>DS30FP</b>	
	30 A DH ⑤	DS30FP
	60 A DH ⑤	DS60FP
	100 A DH ⑤	DS100FP
	200 A DH ⑤	DS200FP
<b>"J" Fuse Adapter Kits ⑦⑧</b>		
	<b>DS22JK</b>	
	60 A 240 V DH ⑤	DS22JK
	60 A DH, DT and receptacle switches ⑤	DS26JK
	400 A 600 V DT ⑤	DT400JK
600 A 240–600 V DH, 600 A DG ⑥	DS600JK	
<b>"R" Fuse Adapter Kits 4</b>		
	<b>DS12FK</b>	
	30 A DG	DG030RB
	100 A DG	DG100RB
	30 A 240 V DH, DT	DS12FK
	30 A 600 V DH, DT, 60 A 240 V DH, DT, 60 A DG	DS16FK
	60 A 600 V DH, DT	DS26FK
	100 A 240–600 V DH, DT	DS36FK
	200 A 240–600 V DH, DT, 200 A DG	DS46FK
400 A 240–600 V DH, 240 V DT, 400 A DG	DS56FK	
600 A 240–600 V DH, DT, 600 A DG	DS66FK	
<b>"T" Fuse Adapter Kits</b>		
	<b>DS426TK</b>	
	200 A 240 V DH ⑤	DS426TK
	200 A 600 V DH ⑤	DS466TK
	400 A 240 V DG, DH, DT ⑥	DS526TK
	400 A 600 V DH ⑥	DS566TK
	600 A 240 V DG, DH ⑥	DS626TK
	600 A 600 V DH ⑥	DS666TK
	600 A 240 V DT ⑥	DT626TK
	600 A 600 V DT ⑥	DT666TK
	800 A 240 V DH ⑥	DS726TK
800 A 600 V DH, DT ⑥	DS766TK	
<b>Miscellaneous Kits</b>		
Hookstick handle	DH800HSH	
Lubricating grease for safety switch blades and contacts (each kit contains three 30 cc tubes of lubricating grease)	DSLUBEKIT	

- ① Service entrance bonding kit and sticker are included with the neutral kit.
  - ② Ground bar kit is not listed on device publications.
  - ③ Order one kit per switch.
  - ④ For duty ratings, see table on following page.
  - ⑤ Order one kit for three poles.
  - ⑥ Order one kit for each pole.
  - ⑦ 30 A Class J available as factory option only.
  - ⑧ If Class J fuse kit is not listed, then switch will accept Class J fusing by repositioning either fuse base or fuse clips. No drilling required.
  - ⑨ Order one kit for six poles.
- Note:** Accessories are not applicable to NEMA 7/9 switches unless indicated otherwise.

**Auxiliary Contact Rating**

**Table 28.1-5. AC Pilot Duty Ratings**

Description	Volts	Break (Amperes)	Make (Amperes)	Catalog Number
1NO-1NC	110	15.0	40.0	DS200EK1
1NO-1NC	220	10.0	20.0	DS200EK1
1NO-1NC	440	6.0	10.0	DS200EK1
1NO-1NC	600	5.0	8.0	DS200EK1
2NO/2NC	110	3.0	30.0	DS200EK2
2NO/2NC	220	1.5	15.0	DS200EK2
2NO/2NC	440	1.0	8.0	DS200EK2
2NO/2NC	600	0.8	6.0	DS200EK2

**Table 28.1-6. DC Pilot Duty Ratings**

Description	Volts	Single Throw (Amperes)	Double Throw (Amperes)	Catalog Number
1NO-1NC	115	2.0	0.5	DS200EK1
1NO-1NC	230	0.5	0.2	DS200EK1
1NO-1NC	600	0.1	0.02	DS200EK1
2NO/2NC	115	1.0	0.2	DS200EK2
2NO/2NC	230	0.3	0.1	DS200EK2
2NO/2NC	600	0.1	—	DS200EK2

**Table 28.1-7. Myers Type Hubs—Dimensions in Inches (mm)**

NEMA 3R (400 A and above)  
NEMA 4, 4X (stainless steel), 12

	Conduit Size	Catalog Number
 <p><b>DS050MH</b></p>	0.50 (12.7)	DS050MH
	0.75 (19.1)	DS075MH
	1.00 (25.4)	DS100MH
	1.25 (31.8)	DS125MH
	1.50 (38.1)	DS150MH
	2.00 (50.8)	DS200MH
	2.50 (63.5)	DS250MH
	3.00 (76.2)	DS300MH
	3.50 (88.9)	DS350MH
	4.00 (101.6)	DS400MH
5.00 (127.0)	DS500MH	

**Table 28.1-8. Plate Type Hubs—Dimensions in Inches (mm)**

For NEMA 3R enclosures (up to 200 A)

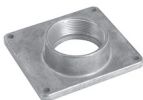
	Group 1 General-Duty, Heavy-Duty, Double-Throw Through 100 A		Group 2 General-Duty, Heavy-Duty, Double-Throw Through 200 A	
	Conduit Size	Catalog Number	Conduit Size	Catalog Number
 <p><b>DS075H1</b></p>	0.75 (19.1)	DS075H1	2.00 (50.8)	DS200H2
	1.00 (25.4)	DS100H1	2.50 (63.5)	DS250H2
	1.25 (31.8)	DS125H1	3.00 (76.2)	DS300H2
	1.50 (38.1)	DS150H1	—	—
	2.00 (50.8)	DS200H1	—	—

**Note:** Catalog number DS900AP adapter kit permits installation of Group 1 hubs on 200 A type general-duty, heavy-duty and double-throw switches.



## Flex Center

### Introduction

The Switching Device Flex Center is a special facility at the site of Eaton’s Cleveland, Tennessee plant that is dedicated to providing customized safety switches and enclosed breakers that meet customer’s challenging applications.

**Table 28.1-9. Common Flex Center Design Offerings**

Modification	Catalog Suffix	Description
Custom paint	(varies)	Special paint colors are available such as red, orange, yellow, green, black, white. Other colors may be available upon request. Custom color is applied over the standard ANSI-61 gray finish.
Nameplates	-00NP	Plastic or phenolic nameplates are available. Up to three lines of text, 25 characters per line. Standard offering is white with black letters. Custom colors and sizes available upon request. Specify text at order entry.
Lock on provisions	-00LO	Available on heavy-duty and double-throw safety switches. Provision will accept a single lock.
Trapped key interlock	-00TK	Available on heavy-duty and double-throw safety switches. Trapped key systems are used on safety switches to prevent unauthorized operations or to predetermine a series of power transfers by an authorized operator.
Upper viewing window	W	An upper viewing window is centered over the switching contacts to provide visual verification of ON/OFF status. Available on NEMA 12/3R and NEMA 4X stainless steel heavy-duty and double-throw safety switches. <b>Note:</b> 30–100 A switches are now provided with a full view cover window for both blade and blown fuse viewing.
Lower viewing window	LW	A lower viewing window is centered over the fuses and provides visual verification of blown fuse indicators. Available on 200–1200 A NEMA 12/3R and NEMA 4X stainless steel heavy-duty and double-throw safety switches. Available for fusible switches only. <b>Note:</b> 30–100 A switches are now provided with a full view cover window for both blade and blown fuse viewing.
Neutral assemblies	N	Factory-installed field neutral accessory kits. Add Suffix N on non-fusible switches, or replace the 6th character “F” with “N” on fusible switches.
Class “R” fuse clips	5 or 6	Factory-installed Class R fuse clips/provisions. Add Suffix 5 for 240 V switches, and Suffix 6 for 600 V switches. Available on 30–600 A safety switches.
Class “T” fuse clips	T	Factory-installed Class T fuse clips/provisions. Available on 200–1200 A safety switches.
Class “J” fuse clips	J	Factory-installed Class J fuse clips/provisions. Available on 30–600 A safety switches. <b>Note:</b> Field modification kits are not available for 30 A heavy-duty safety switches. 30 A switches requiring Class J fusing must be ordered factory installed with J suffix.
Fungus proofing	-00FP	All non-metallic components of the switch are coated with a moisture and fungus-resistant varnish. The inhibitor used meets military specification: MIL-V-173C for MOISTURE AND FUNGUS-RESISTANT TREATMENT. The treated switch meets military specification MIL-T-152E for MOISTURE AND FUNGUS-RESISTANT TREATMENT OF COMMUNICATIONS, ELECTRONICS, AND ASSOCIATED EQUIPMENT. Not UL Listed.
Fuse pullers	FE	Factory-installed fuse pullers. <b>Note:</b> Standard NEMA 12/3R and 4X switches 30–200 A are supplied with fuse pullers from the factory.
Crimp lug pads	-00CK	Factory-installed crimp lug pad kits. Available on 400–800 A safety switches. Crimp lugs are not included. <b>Note:</b> Standard heavy-duty Type DH switches 30–200 A are adaptable to crimp lugs; simply remove the box lugs.
Copper lugs	-00CL	Factory-installed copper lug kits. Available on 30–800 A safety switches.
Ground lug kits factory installed	G	Factory-installed ground lug kits. Provides additional ground lug capacity when compared to ground lugs that come with standard safety switches. Available on 30–1200 A safety switches.
Custom lugs	-000L	Customer-specified lug arrangements are available on heavy-duty and double-throw safety switches.
Auxiliary contacts	2 or 3	Factory-installed auxiliary contact kits (DS200EK1 or DS200EK2). Auxiliary contacts are Early-Make/Early-Break operation. To specify 1NO/1NC contact, add Suffix 2. To specify 2NO/2NC contacts, add Suffix 3.
Control pole	-00CP	The K-Series control pole provides one NO contact. It mounts in the exact location as the neutral block using the same pre-drilled holes. This is directly connected to the power pole operating shaft. Direct connection and visible blades provide more secure electrical interlocking than handle linkage operation of a snap/switch type interlock. This reliability meets the requirements of many specifications for four-pole switches when the fourth pole is required for secure electrical interlocking. This control pole provides Same-Make/Same-Break operation.
Control pole with offset	-0CP2	Same as above except this control pole provides Late-Make/Early-Break operation. Both Control Pole options are provided when you purchase the DS16CP field kit.
Switching neutral double throws	SN	UL Listed for three-pole and four-pole non-fusible double-throw safety switches. Switching neutrals are required for separately derived systems when bonding the neutral of the generator to a grounding system at the generator.
Surge protection	(varies)	Factory-installed Eaton Type 1 (SP1 series) or Type 2 (CVX series) surge protective device products. SPD installed and wired to load side of disconnect.

### Additional Flex Center Design Offerings

- Left-hand design (30–200 A)
- Cover controls
- 200% neutrals
- Seam-welded stainless steel
- Quick Connect products with Cam-Lok and Posi-Lok receptacles
- Custom enclosures
- 316 grade stainless steel
- Mill-duty switches
- Irrigation switches
- Fuses installed
- Hook stick handles (heavy-duty switches only)
- Custom labels
- Custom mounting
- Pad-mount designs
- Non-standard receptacles
- Enhanced visible blade
- Voltage indicators

### Contact

For more information on these or any other modifications, please contact the Switching Device Flex Center at 1-888-329-9272, email FlexSwitches@eaton.com or visit Eaton.com/FlexCenter.

General-Duty

Table 28.1-10. General-Duty, Non-Fusible, 240 V, Three-Pole, Single-Throw

Ampere Rating	NEMA 1					NEMA 3R				
	Dimensions in Inches (mm)				Weight Lb (kg)	Dimensions in Inches (mm)				Weight Lb (kg)
	Width (W)	Height (H)	Depth (D)	Depth (D2)		Width (W)	Height (H)	Depth (D)	Depth (D2)	
30	6.38 (162.1)	10.69 (271.5)	6.88 (174.8)	3.75 (95.2)	6 (2.724)	6.38 (162.1)	10.81 (274.6)	6.88 (174.8)	3.75 (95.2)	6 (2.724)
60	8.69 (220.7)	14.19 (360.4)	7.38 (187.5)	4.21 (106.9)	9 (4.086)	8.69 (220.7)	14.38 (365.3)	7.38 (187.5)	4.21 (106.9)	9 (4.086)
100	9.13 (231.9)	18.81 (477.8)	7.38 (187.5)	4.23 (107.4)	12 (5.448)	9.13 (231.9)	19.25 (489.0)	7.38 (187.5)	4.23 (107.4)	12 (5.448)
200	16.00 (406.4)	25.25 (641.4)	11.25 (285.8)	6.14 (156.0)	48 (21.792)	16.00 (406.4)	25.50 (647.7)	11.25 (285.8)	6.14 (156.0)	55 (24.97)
400	23.00 (584.2)	44.75 (1136.7)	12.63 (320.8)	7.27 (184.7)	100 (45.4)	23.00 (584.2)	45.19 (1147.8)	12.63 (320.8)	7.27 (184.7)	105 (47.67)
600	24.00 (609.6)	52.25 (1327.2)	14.25 (362.0)	8.95 (227.3)	130 (59.02)	24.00 (609.6)	52.70 (1338.6)	14.25 (362.0)	8.95 (227.3)	135 (61.29)

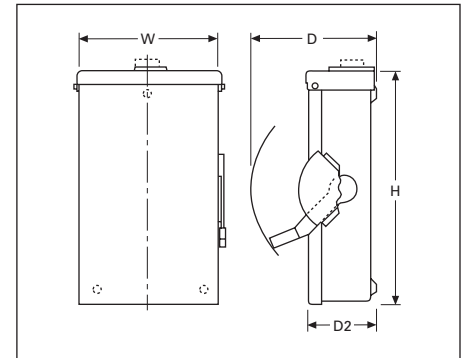

Figure 28.1-1. NEMA 1-3R 30-100 A

Table 28.1-11. General-Duty, Fusible, 240 V, Three-Pole, Solid Neutral, Single-Throw

Ampere Rating	NEMA 1					NEMA 3R				
	Dimensions in Inches (mm)				Weight Lb (kg)	Dimensions in Inches (mm)				Weight Lb (kg)
	Width (W)	Height (H)	Depth (D)	Depth (D2)		Width (W)	Height (H)	Depth (D)	Depth (D2)	
30	6.38 (162.1)	10.69 (271.5)	6.88 (174.8)	3.75 (95.2)	6 (2.724)	6.38 (162.1)	10.81 (274.6)	6.88 (174.8)	3.75 (95.2)	6 (2.724)
60	8.68 (220.7)	14.19 (360.4)	7.38 (187.5)	4.21 (106.9)	10 (4.54)	8.69 (220.7)	14.38 (365.3)	7.38 (187.5)	4.21 (106.9)	10 (4.54)
100	9.13 (231.9)	18.81 (477.8)	7.38 (187.5)	4.23 (107.4)	14 (6.356)	9.13 (231.9)	19.25 (489.0)	7.38 (187.5)	4.23 (107.4)	14 (6.356)
200	16.00 (406.4)	24.75 (628.7)	11.25 (285.8)	6.14 (156.0)	48 (21.792)	16.00 (406.4)	25.50 (647.7)	11.25 (285.8)	6.14 (156.0)	55 (24.97)
400	23.00 (584.2)	44.75 (1136.7)	12.63 (320.8)	7.27 (184.7)	110 (49.94)	23.00 (584.2)	45.19 (1147.8)	12.63 (320.8)	7.27 (184.7)	115 (52.21)
600	24.00 (609.6)	52.25 (1327.2)	14.25 (362.0)	8.95 (227.3)	145 (65.83)	24.00 (609.6)	52.70 (1338.6)	14.25 (362.0)	8.95 (227.3)	150 (68.1)

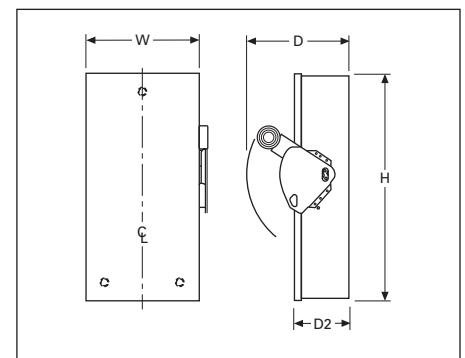

Figure 28.1-2. NEMA 1-3R 200-600 A

Note: Not applicable to plug fuse.

Heavy-Duty

Approximate Dimensions in Inches (mm)

Table 28.1-12. Heavy-Duty, Non-Fusible, 600 V, Three-Pole, Single-Throw ①

Ampere Rating	NEMA 1, 3R					NEMA 12, 4X Stainless Steel, 4				
	Dimensions in Inches (mm)				Weight Lb (kg)	Dimensions in Inches (mm)				Weight Lb (kg)
	Width (W)	Height (H)	Depth (D)	Depth (D2)		Width (W)	Height (H)	Depth (D)	Depth (D2)	
30	8.13 (206.5)	15.88 (403.4)	10.00 (254.0)	5.25 (133.3)	16 (7.264)	8.13 (206.5)	12.13 (308.1)	10.00 (254.0)	5.50 (139.7)	17 (7.718)
60	8.13 (206.5)	15.88 (403.4)	10.00 (254.0)	5.25 (133.3)	16 (7.264)	8.13 (206.5)	12.13 (308.1)	10.00 (254.0)	5.50 (139.7)	17 (7.718)
100	11.13 (282.7)	21.69 (550.9)	10.00 (254.0)	5.25 (133.3)	22 (9.988)	11.13 (282.7)	24.00 (609.6)	10.25 (260.4)	5.50 (139.7)	28 (12.712)
200	16.00 (406.4)	27.63 (701.8)	11.25 (285.8)	6.14 (156.0)	46 (20.884)	16.00 (406.4)	34.38 (873.3)	11.50 (292.1)	6.44 (163.6)	55 (24.97)
400	23.00 (584.2)	45.19 (1147.8)	12.63 (320.8)	7.27 (184.7)	110 (49.94)	23.00 (584.2)	57.63 (1463.8)	12.63 (320.8)	7.19 (182.6)	125 (56.75)
600	24.00 (609.6)	52.70 (1338.6)	14.25 (362.0)	8.95 (227.3)	135 (61.29)	24.00 (609.6)	63.00 (1600.2)	14.25 (362.0)	8.88 (225.6)	167 (75.818)
800	25.38 (644.7)	56.69 (1439.9)	14.25 (362.0)	8.95 (227.3)	158 (71.732)	25.38 (644.7)	71.75 (1822.5)	14.25 (362.0)	8.88 (225.6)	175 (79.45)
1200	41.47 (1053.3)	70.31 (1785.9)	19.94 (506.5)	12.44 (316.0)	430 (195.22)	41.47 (1053.3)	70.31 (1785.9)	19.94 (506.5)	13.51 (343.2)	475 (215.65)

① Data applicable to heavy-duty and enhanced visible blade switches.

Table 28.1-13. Heavy-Duty, Fusible, 240 and 600 V, Three-Pole Solid Neutral, Single-Throw ②

Ampere Rating	NEMA 1, 3R					NEMA 12, 4X Stainless Steel, 4				
	Dimensions in Inches (mm)				Weight Lb (kg)	Dimensions in Inches (mm)				Weight Lb (kg)
	Width (W)	Height (H)	Depth (D)	Depth (D2)		Width (W)	Height (H)	Depth (D)	Depth (D2)	
30	8.13 (206.5)	15.88 (403.4)	10.00 (254.0)	5.25 (133.3)	20 (9.08)	8.13 (206.5)	17.88 (454.2)	10.00 (254.0)	5.50 (139.7)	22 (9.988)
60	8.13 (206.5)	15.88 (403.4)	10.00 (254.0)	5.25 (133.3)	20 (9.08)	8.13 (206.5)	17.88 (454.2)	10.00 (254.0)	5.50 (139.7)	22 (9.988)
100	11.13 (282.7)	21.69 (550.9)	10.00 (254.0)	5.25 (133.3)	27 (12.258)	11.13 (282.7)	24.00 (609.6)	10.25 (260.4)	5.50 (139.7)	30 (13.62)
200	16.00 (406.4)	27.63 (701.8)	11.25 (285.8)	6.14 (156.0)	52 (23.608)	16.00 (406.4)	34.38 (873.3)	11.50 (292.1)	6.44 (163.6)	61 (27.694)
400	23.00 (584.2)	45.19 (1147.8)	12.63 (320.8)	7.27 (184.7)	120 (54.48)	23.00 (584.2)	57.63 (1463.8)	12.63 (320.8)	7.19 (182.6)	135 (61.29)
600	24.00 (609.6)	52.70 (1338.6)	14.25 (362.0)	8.95 (227.3)	153 (69.462)	24.00 (609.6)	63.00 (1600.2)	14.25 (362.0)	8.88 (225.6)	203 (92.162)
800	25.38 (644.7)	56.69 (1439.9)	14.25 (362.0)	8.95 (227.3)	168 (76.272)	25.38 (644.7)	71.75 (1822.5)	14.25 (362.0)	8.88 (225.6)	213 (96.702)
1200	41.47 (1053.3)	70.31 (1785.9)	19.94 (506.5)	12.44 (316.0)	465 (211.11)	41.47 (1053.3)	70.31 (1785.9)	19.94 (506.5)	13.51 (343.2)	510 (231.54)

② Data applicable to heavy-duty and enhanced visible blade switches.

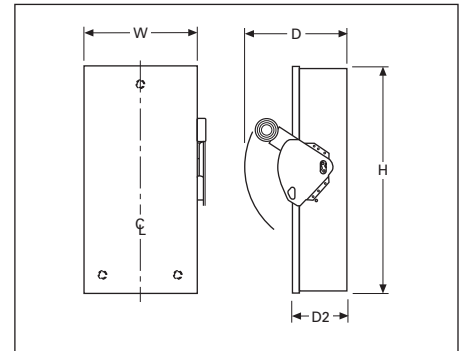

Figure 28.1-3. NEMA 1, 3R 30–1200 A

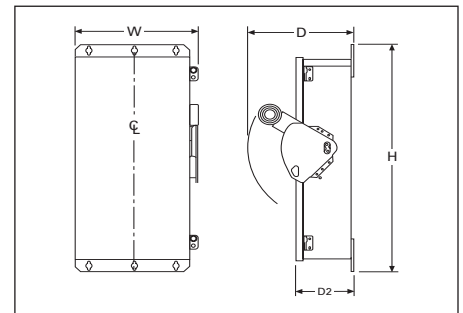

Figure 28.1-4. NEMA 4/4X and 12 30–1200 A



### Heavy-Duty Safety Switches with Surge Protection

Approximate Dimensions in Inches (mm)

**Table 28.1-14. Heavy-Duty Safety Switches with Surge Protection**

Ampere rating	Height (H)	Width (W)	Depth (D1)	Depth (D2)
30	25.02 (635.5)	15.00 (381.0)	10.31 (261.9)	5.62 (142.7)
60	25.02 (635.5)	15.00 (381.0)	10.31 (261.9)	5.62 (142.7)
100	25.02 (635.5)	15.00 (381.0)	10.31 (261.9)	5.62 (142.7)
200	35.37 (898.4)	20.44 (519.2)	11.66 (296.2)	6.48 (164.6)
400	57.47 (1459.7)	23.30 (591.8)	12.45 (316.2)	7.36 (186.9)
600	62.97 (1599.4)	24.30 (617.2)	14.08 (357.6)	8.98 (228.1)
800	71.72 (1821.7)	25.55 (649.0)	14.08 (357.6)	8.98 (228.1)
1200 ①	73.77 (1873.8)	43.12 (1095.0)	19.20 (487.7)	12.46 (316.5)

① Available with SP1 type surge protective device only.

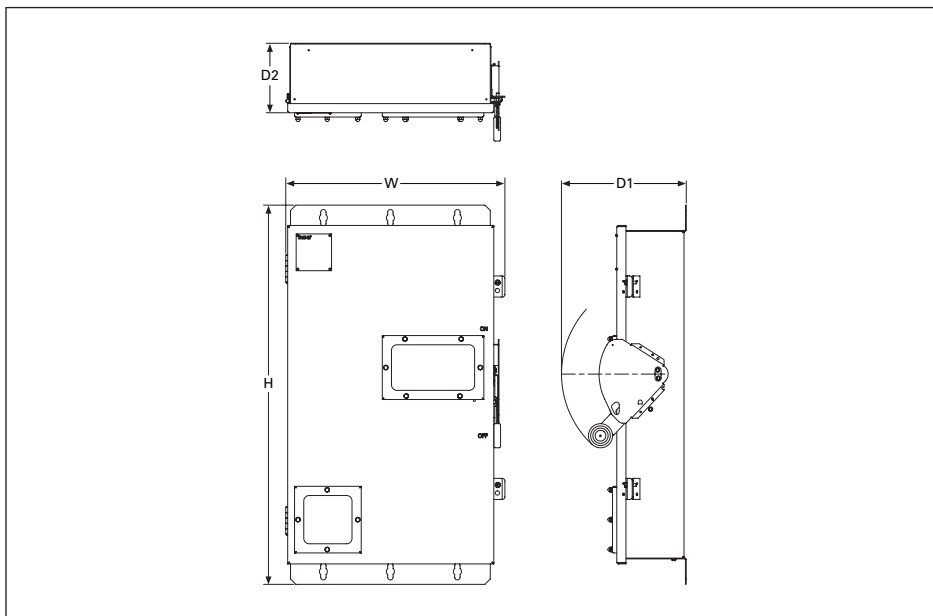

**Figure 28.1-5. Heavy-Duty Safety Switch with Surge Protection**

EnviroLine

Approximate Dimensions in Inches (mm)

Table 28.1-16. Heavy-Duty, Non-Fusible, 600 V, Three-Pole, Single-Throw

Ampere Rating	Width (W)	Height (H)	Depth (D)	Depth (D2)	Weight Lb (kg)
<b>4X Stainless Steel</b>					
30	8.13 (206.5)	12.13 (308.1)	10.00 (254.0)	5.50 (139.7)	17 (7.718)
60	8.13 (206.5)	12.13 (308.1)	10.00 (254.0)	5.50 (139.7)	17 (7.718)
100	11.13 (282.7)	24.00 (609.6)	10.25 (260.4)	5.50 (139.7)	28 (12.712)
200	16.00 (406.4)	34.38 (873.3)	11.50 (292.1)	6.44 (163.6)	55 (24.97)
400	23.00 (584.2)	57.63 (1463.8)	12.63 (320.8)	7.19 (182.6)	125 (56.75)

Table 28.1-17. Heavy-Duty, Fusible, 240 V and 600 V, Three-Pole, Solid Neutral, Single-Throw

Ampere Rating	Width (W)	Height (H)	Depth (D)	Depth (D2)	Weight Lb (kg)
<b>4X Stainless Steel</b>					
30	8.13 (206.5)	17.88 (454.2)	10.00 (254.0)	5.50 (139.7)	22 (9.988)
60	8.13 (206.5)	17.88 (454.2)	10.00 (254.0)	5.50 (139.7)	22 (9.988)
100	11.13 (282.7)	24.00 (609.6)	10.25 (260.4)	5.50 (139.7)	30 (13.62)
200	16.00 (406.4)	34.38 (873.3)	11.50 (292.1)	6.44 (163.6)	61 (27.694)
400	23.00 (584.2)	57.63 (1463.8)	12.63 (320.8)	7.19 (182.6)	135 (61.29)

Table 28.1-18. Heavy-Duty, Non-Fusible, 600 V, Three-Pole, Single-Throw

Ampere Rating	Width (W)	Height (H)	Depth (D)	Depth (D2)	Weight Lb (kg)
<b>NEMA 12/3R, 4, 4X Stainless Steel</b>					
30	8.76 (222.5)	19.08 (484.6)	10.22 (259.6)	5.50 (139.7)	22 (9.988)
60	8.76 (222.5)	19.08 (484.6)	10.22 (259.6)	5.50 (139.7)	22 (9.988)
100	11.79 (299.5)	24.95 (633.7)	10.22 (259.6)	5.50 (139.7)	30 (13.62)
200	16.95 (430.5)	35.38 (898.7)	11.63 (295.4)	6.44 (163.6)	61 (27.694)
400	24.12 (612.6)	57.47 (1459.7)	12.43 (315.7)	7.19 (182.6)	135 (61.29)
600	25.01 (635.3)	62.97 (1599.4)	12.79 (324.9)	8.95 (227.3)	203 (92.162)
800	26.35 (669.3)	71.72 (1821.7)	12.79 (324.9)	8.95 (227.3)	213 (96.702)
1200	43.11 (1095.0)	73.77 (1873.8)	17.15 (435.6)	12.45 (316.2)	510 (231.54)

Approximate Dimensions in Inches (non-window version)  
Dimensions are for estimating purposes only

Table 28.1-19. Heavy-Duty Safety Switches with Weld Receptacle, Fusible and Non-Fusible

Ampere Rating	Width			Height		Depth		Receptacle Brand
	(W1)	(W2)	(W3)	(H1)	(H2)	(D1)	(D2)	
<b>NEMA Type 12/3R, 4X Stainless Steel</b>								
30	8.05	6.75	7.73	19.09	6.67	5.50	10.22	Crouse-Hinds
60	8.05	6.75	7.73	19.09	6.67	5.50	10.22	Crouse-Hinds
100	11.08	9.75	10.76	24.95	7.48	5.50	10.22	Crouse-Hinds
30	8.05	6.75	7.73	19.09	6.13	5.50	10.22	Appleton
60	8.05	6.75	7.73	19.09	6.13	5.50	10.22	Appleton
100	11.08	9.75	10.76	24.95	6.12	5.50	10.22	Appleton
30	9.42	7.50	9.11	26.48	1.62	6.34	11.53	Russellstoll
60	9.42	7.50	9.11	26.48	1.69	6.34	11.53	Russellstoll
100	9.42	7.50	9.11	26.48	1.94	6.34	11.53	Russellstoll

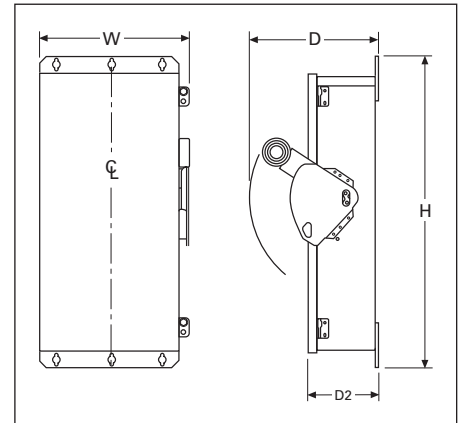

Figure 28.1-6. NEMA 4X Heavy-Duty 30-400 A

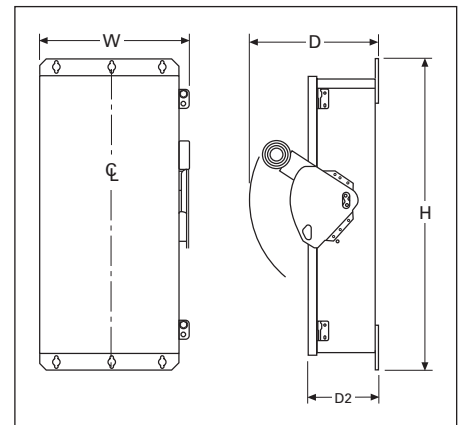

Figure 28.1-7. NEMA 12/3R, 4, 4X Heavy-Duty 30-1200 A

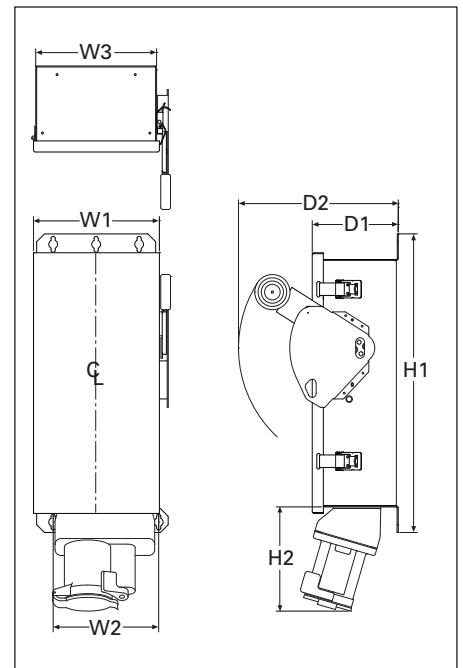
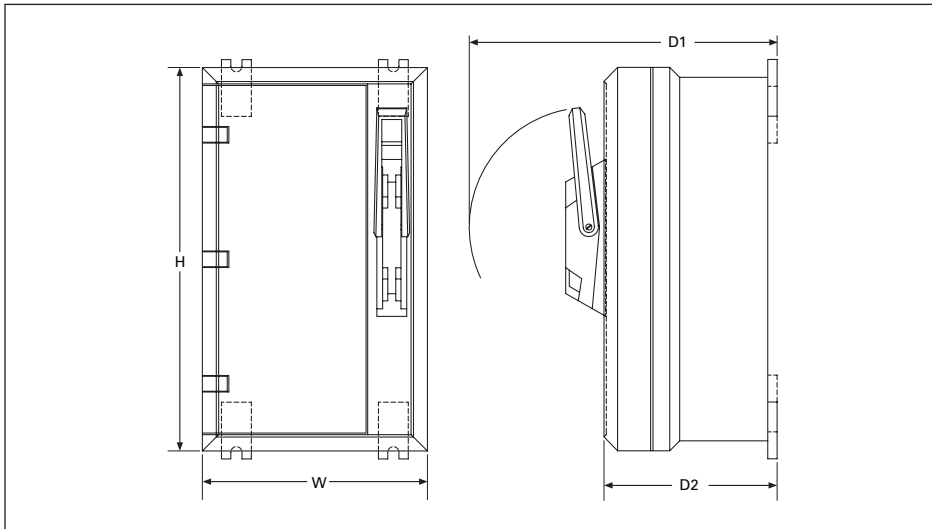

Figure 28.1-8. Receptacle Switches

**Table 28.1-20. Non-Metallic NEMA 4X Rated Safety Switches, Fusible and Non-Fusible**

Ampere Rating	Height	Width	Depth		Weight Lb (kg)
	Height (H)	Width (W)	Depth (D1)	Depth (D2)	
30	19.25 (489.0)	11.30 (287.0)	15.46 (392.7)	8.63 (219.2)	32 (14.5)
60	19.25 (489.0)	11.30 (287.0)	15.46 (392.7)	8.63 (219.2)	32 (14.5)
100	27.25 (692.2)	15.30 (388.6)	16.46 (418.1)	9.70 (246.4)	45 (20.4)
200	27.25 (692.2)	25.30 (642.6)	16.46 (418.1)	9.70 (246.4)	77 (35.0)



**Figure 28.1-9. 240 Vac and 600 Vac Heavy-Duty Non-Metallic**

### Heavy-Duty Double-Throw

Approximate Dimensions in Inches (mm)

**Table 28.1-21. Heavy-Duty, Non-Fusible, 240 V and 600 V, Three-Pole, Double-Throw**

Ampere Rating	Width (W)	Height (H)	Depth (D)	Depth (D2)	Weight Lb (kg)
<b>NEMA 1, 3R</b>					
30	11.94 (303.3)	24.63 (625.6)	9.88 (251.0)	5.38 (136.7)	34 (15.436)
60	11.94 (303.3)	24.63 (625.6)	9.88 (251.0)	5.38 (136.7)	34 (15.436)
100	11.94 (303.3)	24.63 (625.6)	9.88 (251.0)	5.38 (136.7)	34 (15.436)
200	19.56 (496.8)	37.38 (949.5)	11.25 (285.8)	6.10 (154.9)	80 (36.32)
400	23.13 (587.5)	53.81 (1366.8)	12.50 (317.5)	7.25 (184.2)	140 (63.56)
600	27.44 (697.0)	63.31 (1608.1)	14.13 (358.9)	8.88 (225.6)	175 (79.45)
800	27.44 (697.0)	63.31 (1608.1)	14.13 (358.9)	8.88 (225.6)	175 (79.45)
1200	42.62 (1082.5)	78.11 (1984.0)	29.62 (752.3)	20.47 (519.9)	473 (214.6)
<b>NEMA 12, 4X Stainless Steel</b>					
30	12.00 (304.8)	25.88 (657.4)	10.25 (260.4)	5.50 (139.7)	60 (27.24)
60	12.00 (304.8)	25.88 (657.4)	10.25 (260.4)	5.50 (139.7)	60 (27.24)
100	12.00 (304.8)	25.88 (657.4)	10.25 (260.4)	5.50 (139.7)	60 (27.24)
200	19.50 (495.3)	41.00 (1041.4)	11.63 (295.4)	6.48 (164.6)	105 (47.67)
400	23.00 (584.2)	57.50 (1460.5)	12.50 (317.5)	7.25 (184.2)	185 (83.99)

**Table 28.1-22. Heavy-Duty, Fusible, 240 V and 600 V, Three-Pole, Double-Throw**

Ampere Rating	Width (W)	Height (H)	Depth (D)	Depth (D2)	Weight Lb (kg)
<b>NEMA 1, 3R</b>					
30	11.94 (303.3)	36.63 (930.4)	9.88 (251.0)	5.38 (136.7)	44 (19.976)
60	11.94 (303.3)	36.63 (930.4)	9.88 (251.0)	5.38 (136.7)	44 (19.976)
100	11.94 (303.3)	36.63 (930.4)	9.88 (251.0)	5.38 (136.7)	44 (19.976)
200	19.56 (496.8)	50.88 (1292.4)	11.25 (285.8)	6.10 (154.9)	95 (43.13)
400	25.38 (644.7)	74.75 (1898.7)	14.13 (358.9)	8.88 (225.6)	230 (104.42)
600	28.12 (714.3)	58.86 (1495.0)	25.62 (650.7)	20.47 (520.0)	282 (127.9)
800	28.12 (714.2)	58.86 (1495.0)	25.62 (650.7)	20.47 (519.9)	282 (127.9)
1200	42.62 (1082.5)	78.11 (1984.0)	29.62 (752.3)	20.47 (519.9)	509 (230.9)
<b>NEMA 12, 4X Stainless Steel</b>					
30	12.00 (304.8)	39.81 (1011.2)	10.25 (260.4)	5.50 (139.7)	45 (20.43)
60	12.00 (304.8)	39.81 (1011.2)	10.25 (260.4)	5.50 (139.7)	45 (20.43)
100	12.00 (304.8)	39.81 (1011.2)	10.25 (260.4)	5.50 (139.7)	45 (20.43)
200	19.56 (496.8)	55.63 (1413.0)	11.63 (295.4)	6.46 (164.1)	100 (45.4)
400	25.38 (644.7)	74.75 (1898.7)	14.13 (358.9)	8.92 (226.6)	260 (118.04)

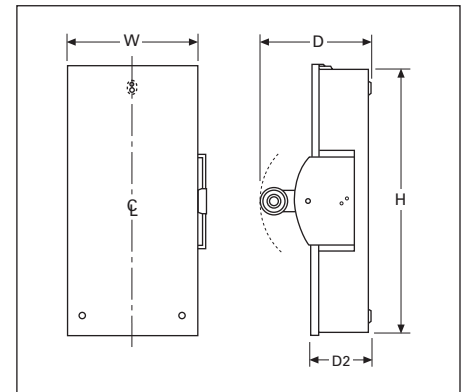

**Figure 28.1-10. NEMA 1, 3R Double-Throw 30–1200 A**

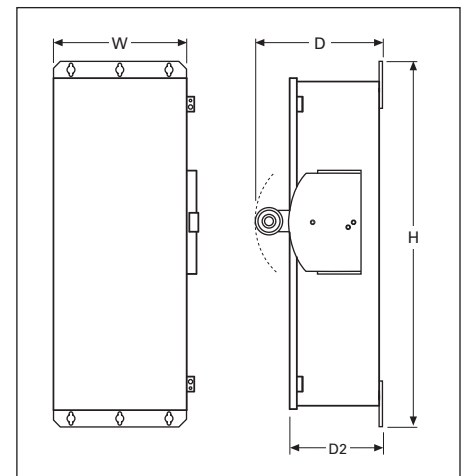

**Figure 28.1-11. NEMA 12, 4X Double-Throw 30–400 A**

### Shunt Trip

Approximate Dimensions in Inches (mm)

**Table 28.1-23. Shunt Trip Safety Switch, 240 Vac and 600 Vac**

Ampere Rating	Fuse Class ①	Number of Poles	Enclosure Dimensions ②, Exterior in Inches (mm)			
			Height (H)	Width (W)	Depth (D1)	Depth (D2)
<b>Fusible</b>						
30	H	2, 3 or 4 ③	21.58 (548.1)	11.58 (294.1)	11.43 (290.3)	5.58 (141.7)
60	H	2, 3 or 4 ③	21.58 (548.1)	11.58 (294.1)	11.43 (290.3)	5.58 (141.7)
100	H	2, 3 or 4 ③	24.95 (633.7)	14.89 (378.2)	11.51 (282.4)	5.58 (141.7)
200	H	2, 3 or 4	35.38 (898.7)	20.11 (510.8)	11.61 (294.9)	6.45 (163.8)
400	H	2, 3 or 4	57.47 (1459.7)	27.29 (693.2)	12.43 (315.7)	7.42 (188.5)
600	H	2, 3 or 4	62.97 (1599.4)	28.29 (718.6)	12.43 (315.7)	7.42 (188.5)
800	L	2, 3	71.72 (1821.7)	29.54 (750.3)	12.43 (315.7)	7.42 (188.5)
1200	L	2, 3	72.50 (1841.5)	47.23 (1199.6)	23.15 (588.0)	12.46 (316.5)
<b>Non-Fusible</b>						
30	—	2, 3 or 4 ③	21.58 (548.1)	11.58 (294.1)	11.43 (290.3)	5.58 (141.7)
60	—	2, 3 or 4 ③	21.58 (548.1)	11.58 (294.1)	11.43 (290.3)	5.58 (141.7)
100	—	2, 3 or 4 ③	24.95 (633.7)	14.89 (378.2)	11.51 (282.4)	5.58 (141.7)
200	—	2, 3 or 4	35.38 (898.7)	20.11 (510.8)	11.61 (294.9)	6.45 (163.8)
400	—	2, 3 or 4	57.47 (1459.7)	27.29 (693.2)	12.43 (315.7)	7.42 (188.5)
600	—	2, 3	62.97 (1599.4)	28.29 (718.6)	12.43 (315.7)	7.42 (188.5)
800	—	2, 3	71.72 (1821.7)	29.54 (750.3)	12.43 (315.7)	7.42 (188.5)
1200	—	2, 3	72.50 (1841.5)	47.23 (1199.6)	23.15 (588.0)	12.46 (316.5)

- ① Class H fuse clips supplied as standard on fusible devices 30–600 A, Class L for 800 A; Class R, J, T fuse clips available.
- ② Accurate for all enclosure NEMA type ratings—12/3R, 4, 4X stainless steel.
- ③ Four-pole devices are wider than dimension for 30, 60 and 100 A devices. Consult factory for details.

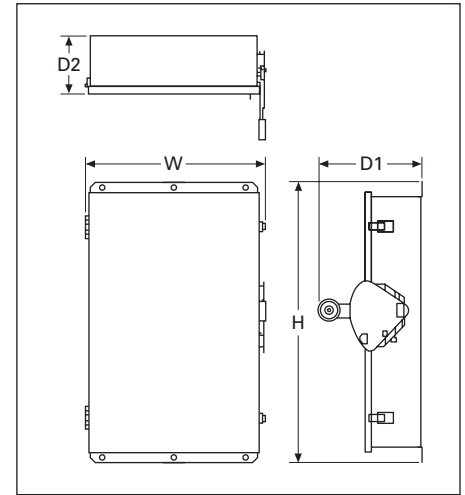

**Figure 28.1-12. Shunt Trip Safety Switch, 240 Vac and 600 Vac**

### Auxiliary Power Heavy-Duty Safety Switch

Approximate Dimensions in Inches (mm)

**Table 28.1-24. Auxiliary Power Heavy Duty Safety Switch**

Ampere Rating	NEMA 3R				Weight Lb (kg)
	Width (W)	Height (H)	Depth (D1)	Depth (D2)	
30	26.58 (675.1)	24.93 (633.2)	16.00 (406.4)	11.29 (286.8)	④
60	26.58 (675.1)	24.93 (633.2)	16.00 (406.4)	11.29 (286.8)	④
100	26.58 (675.1)	24.93 (633.2)	16.00 (406.4)	11.29 (286.8)	④

- ④ 108 lbs (49 kg) with a 15 A GFI receptacle; 130 lbs (59 kg) with a 20 A GFI receptacle.

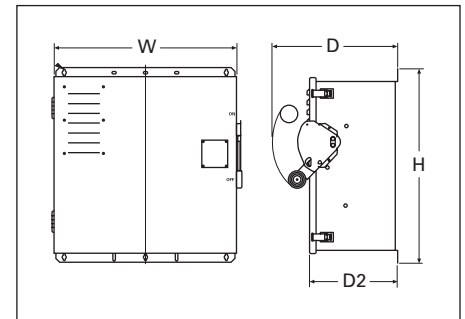

**Figure 28.1-13. Auxiliary Power Heavy-Duty Safety Switch**

Enclosed Rotary

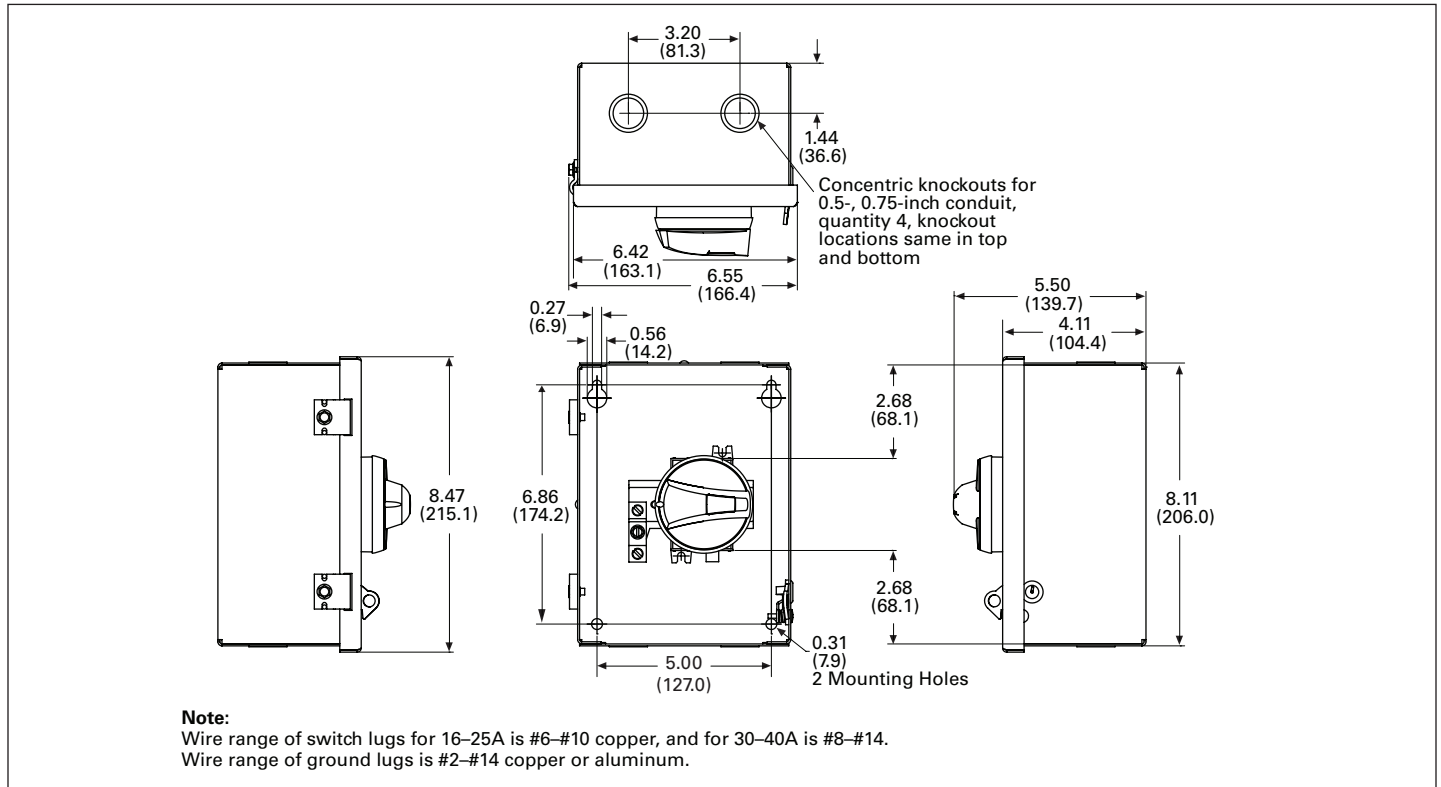

Figure 28.1-14. NEMA Type 1 (16–40 A)

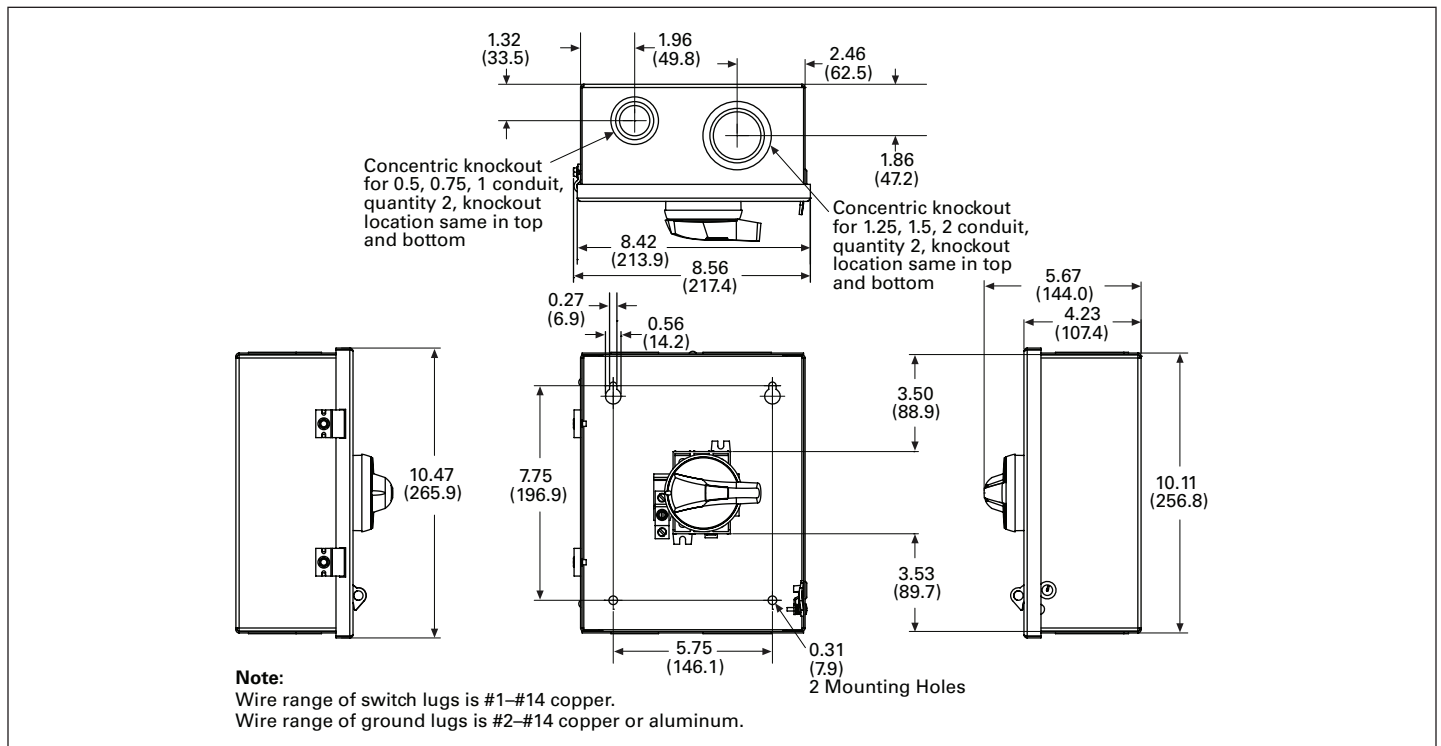

Figure 28.1-15. NEMA Type 1 (60–80 A)

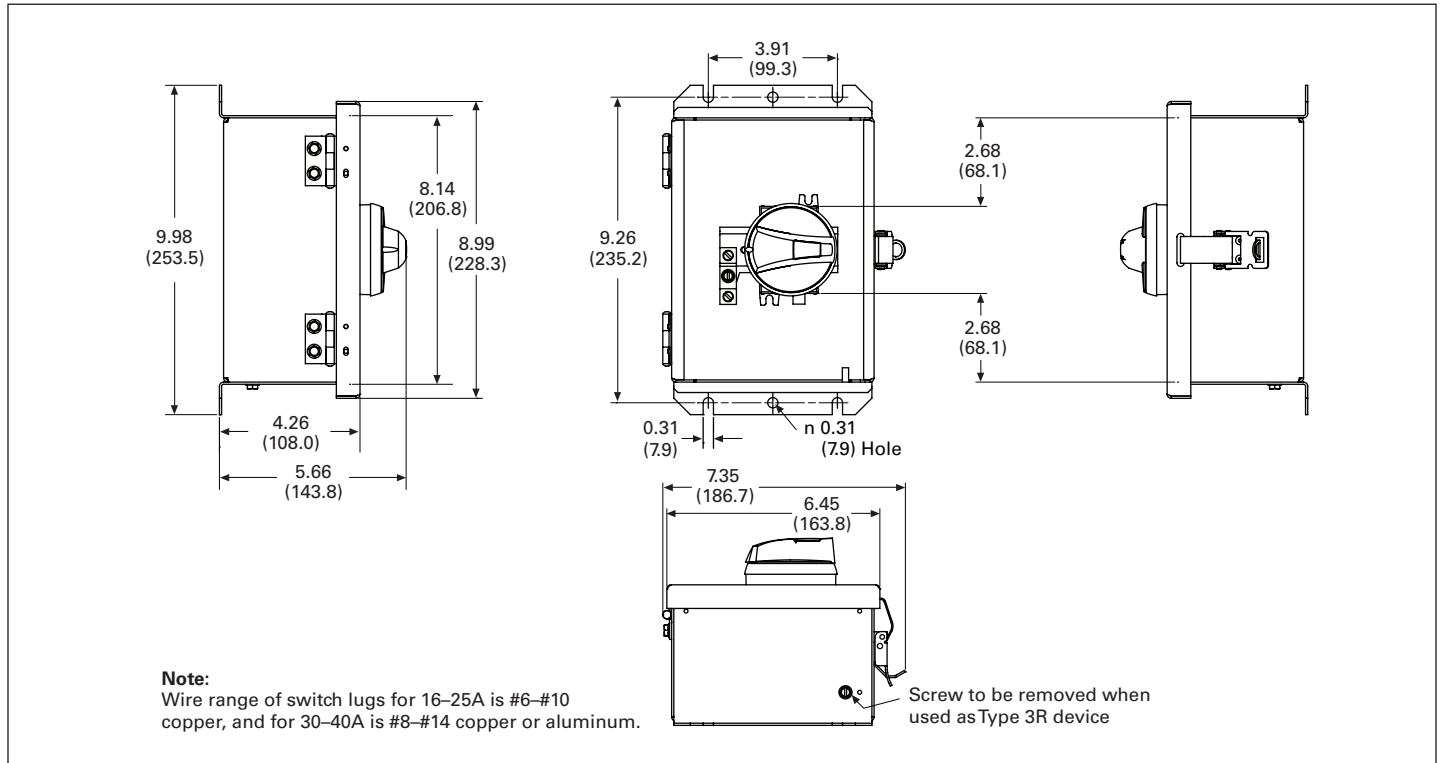

Figure 28.1-16. NEMA Type 12/3R (16–40 A)

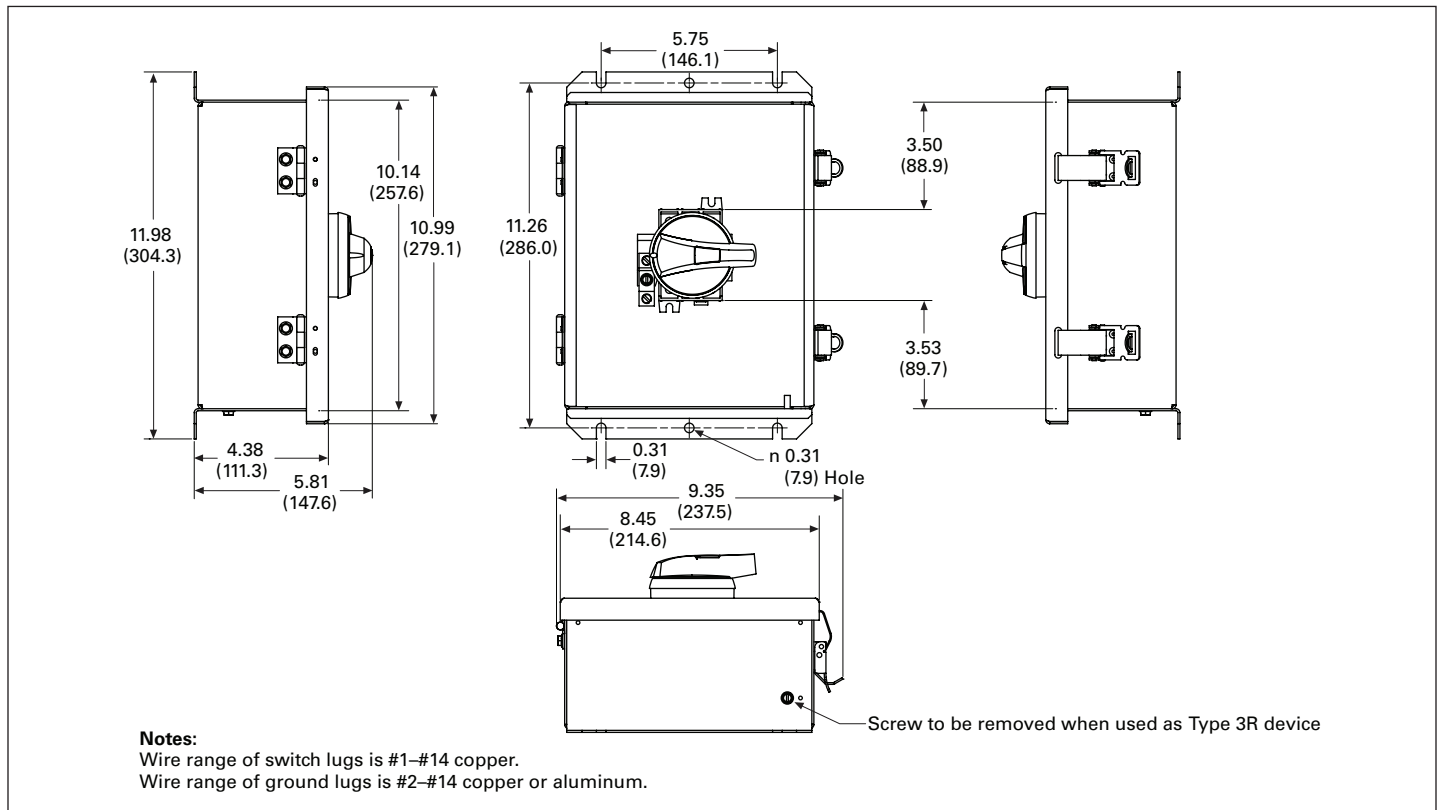

Figure 28.1-17. NEMA Type 12/3R (60–80 A)

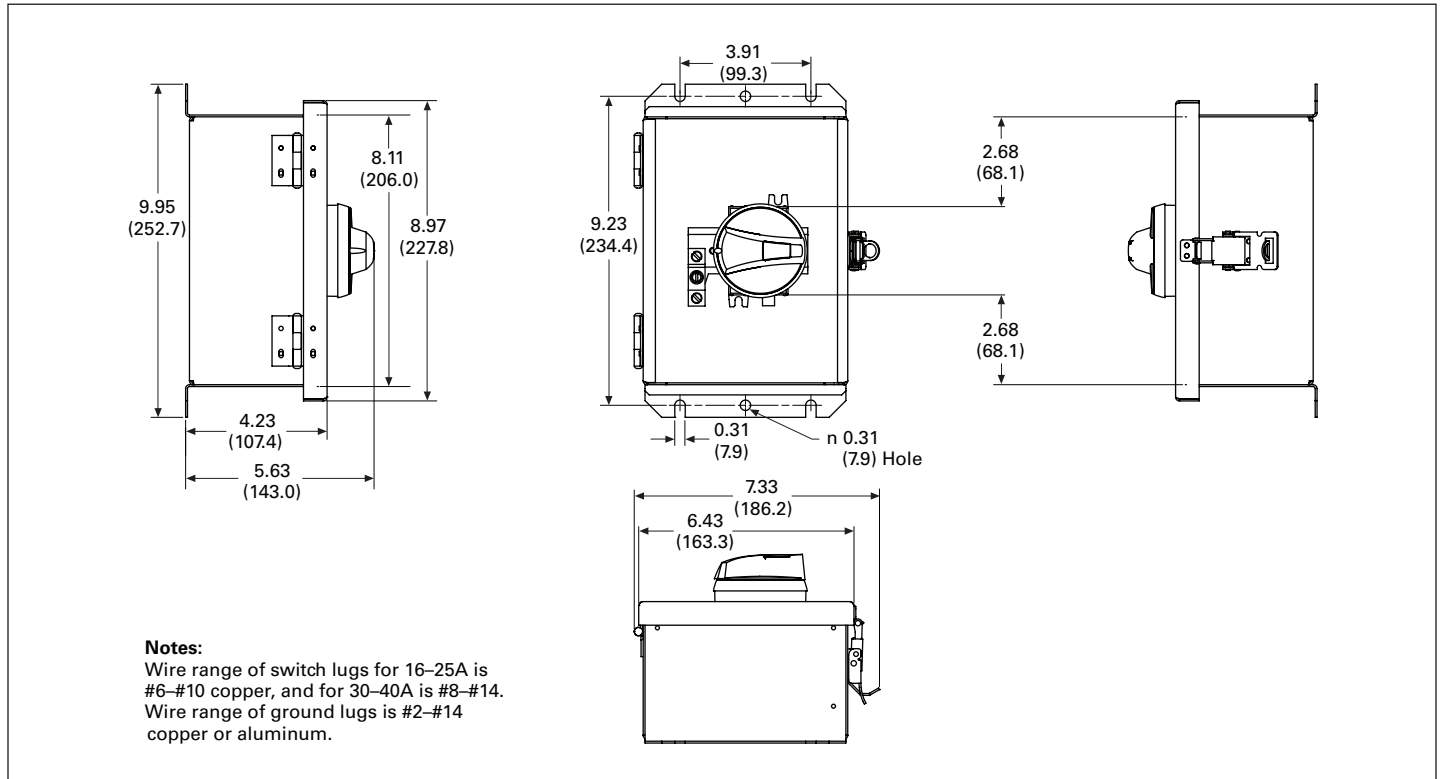

Figure 28.1-18. NEMA Type 4X Stainless (16–40 A)

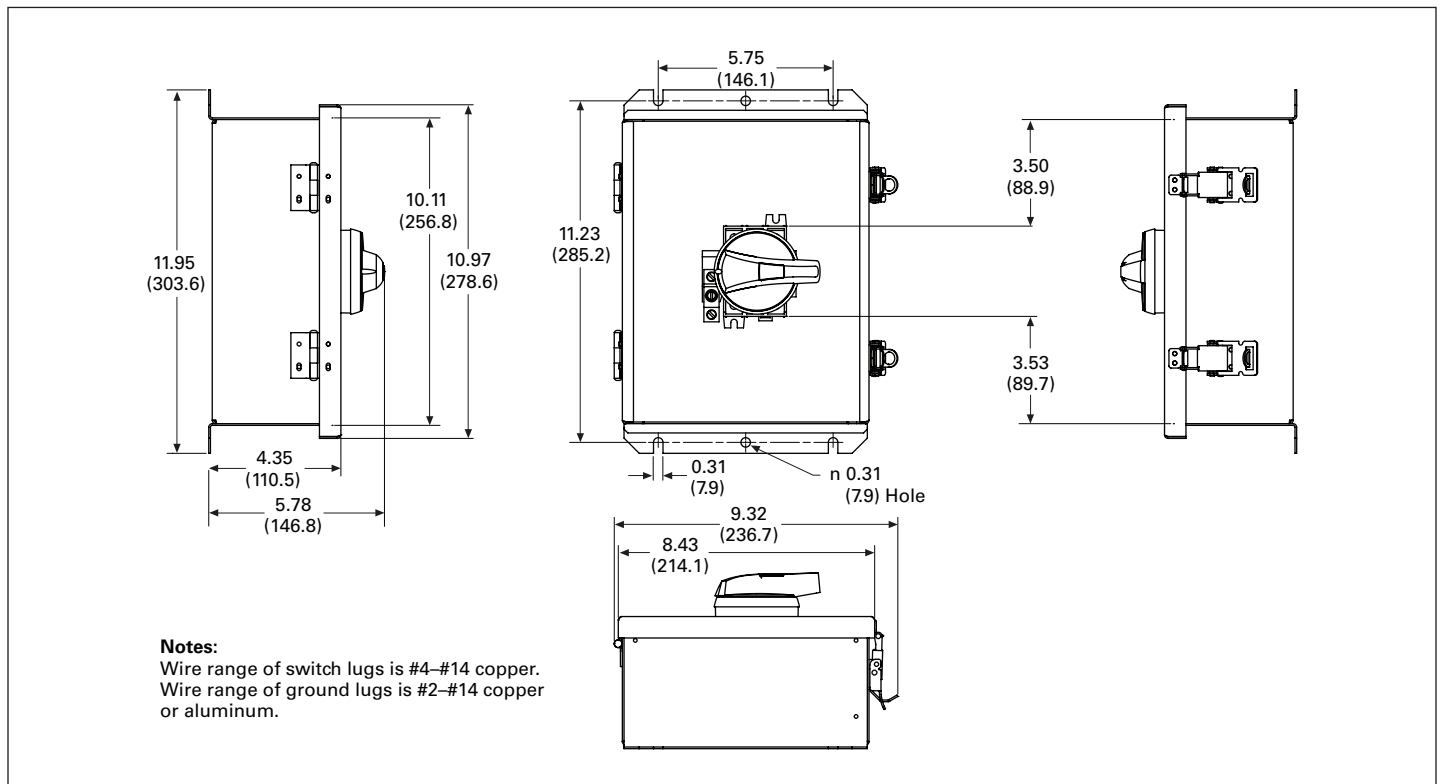

Figure 28.1-19. NEMA Type 4X Stainless (60–80 A)



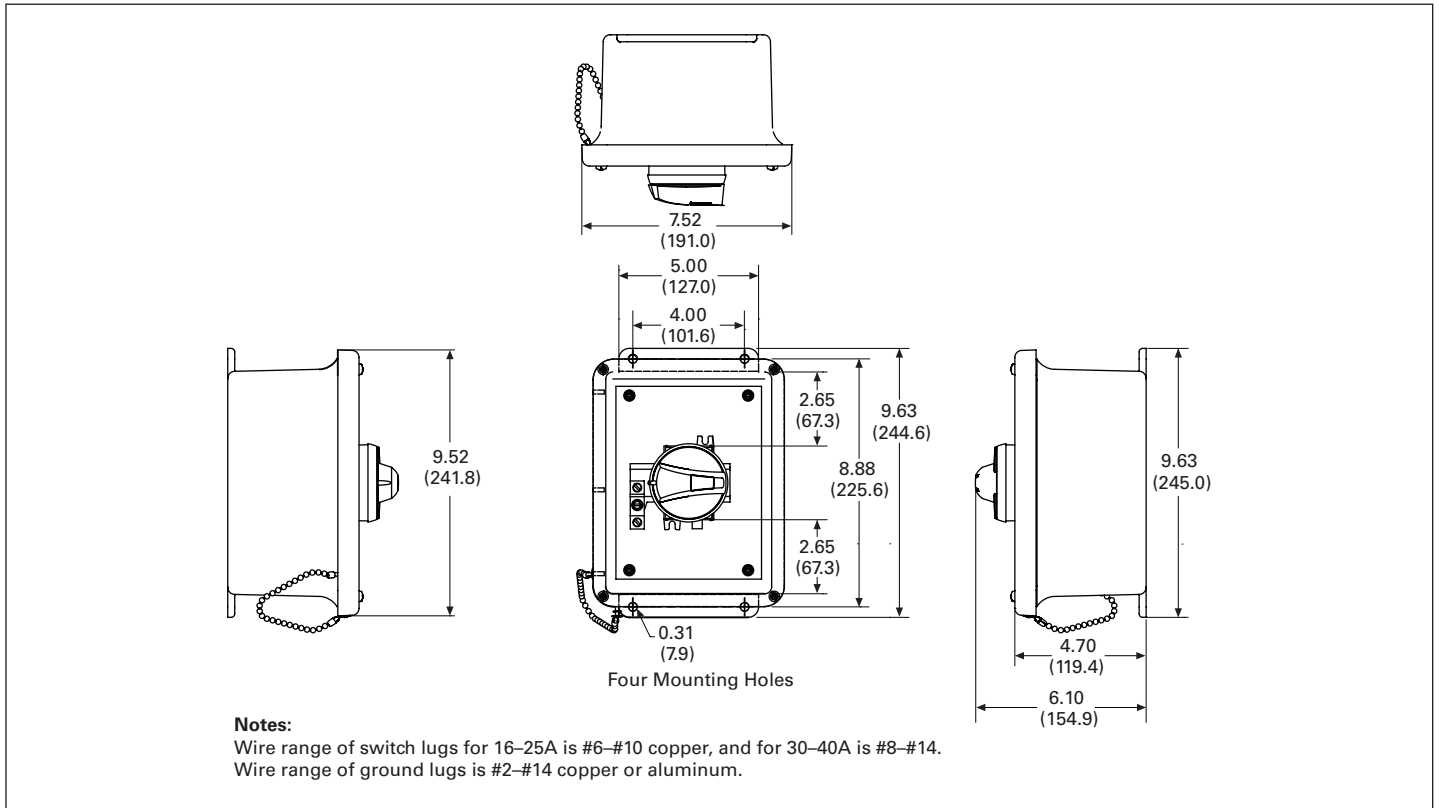

Figure 28.1-20. NEMA Type 4X Thermoset Polyester (16–40 A)

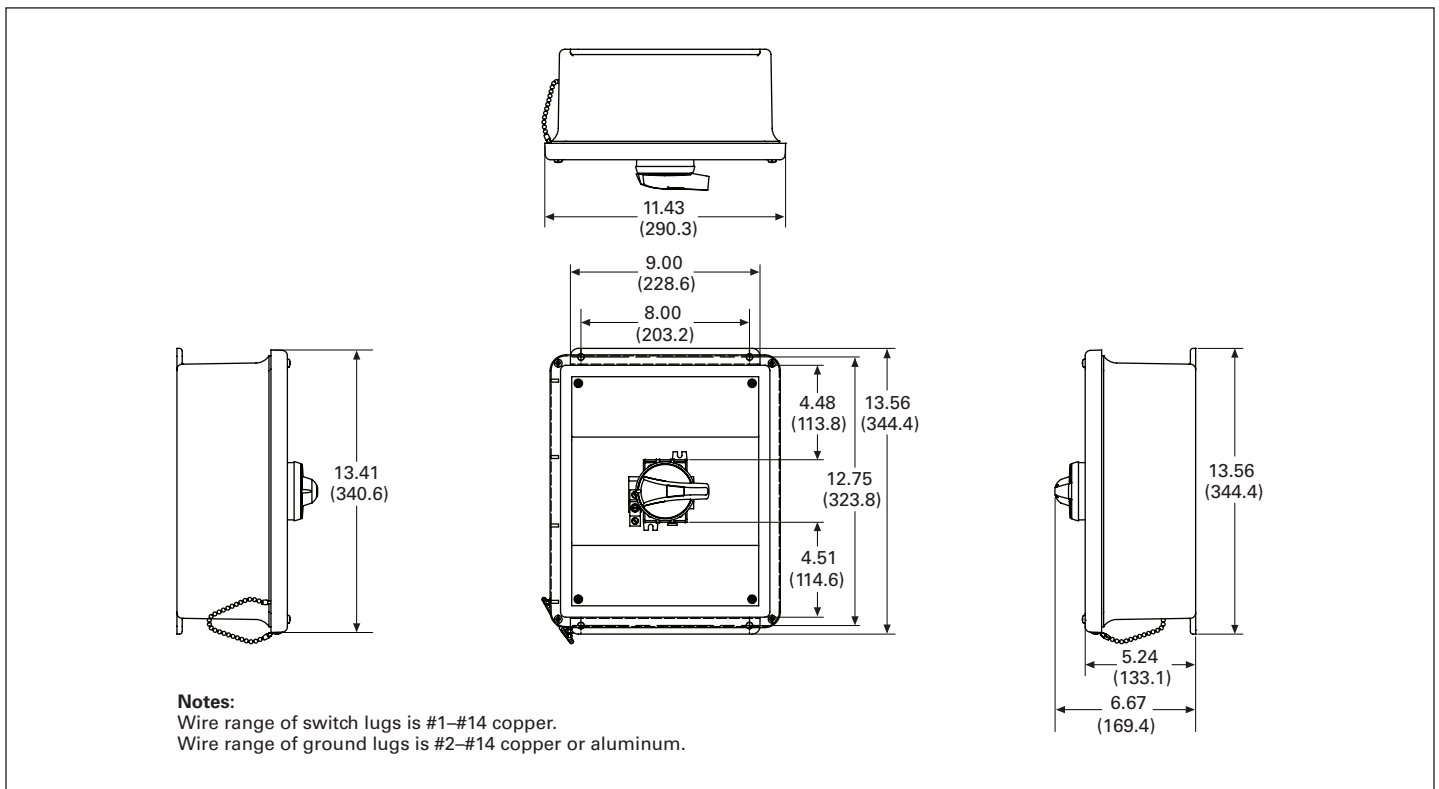

Figure 28.1-21. NEMA Type 4X Thermoset Polyester (60–80 A)

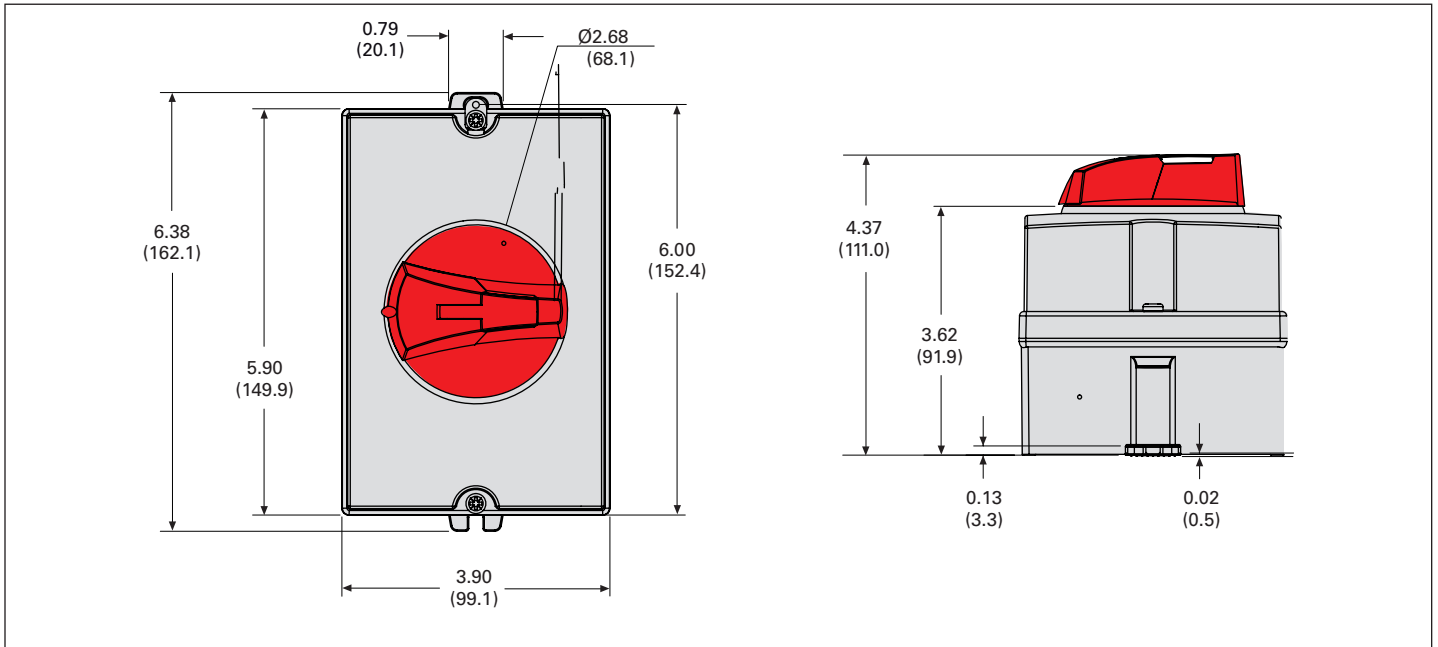

Figure 28.1-22. NEMA Type 4X—Polycarbonate (30 A)

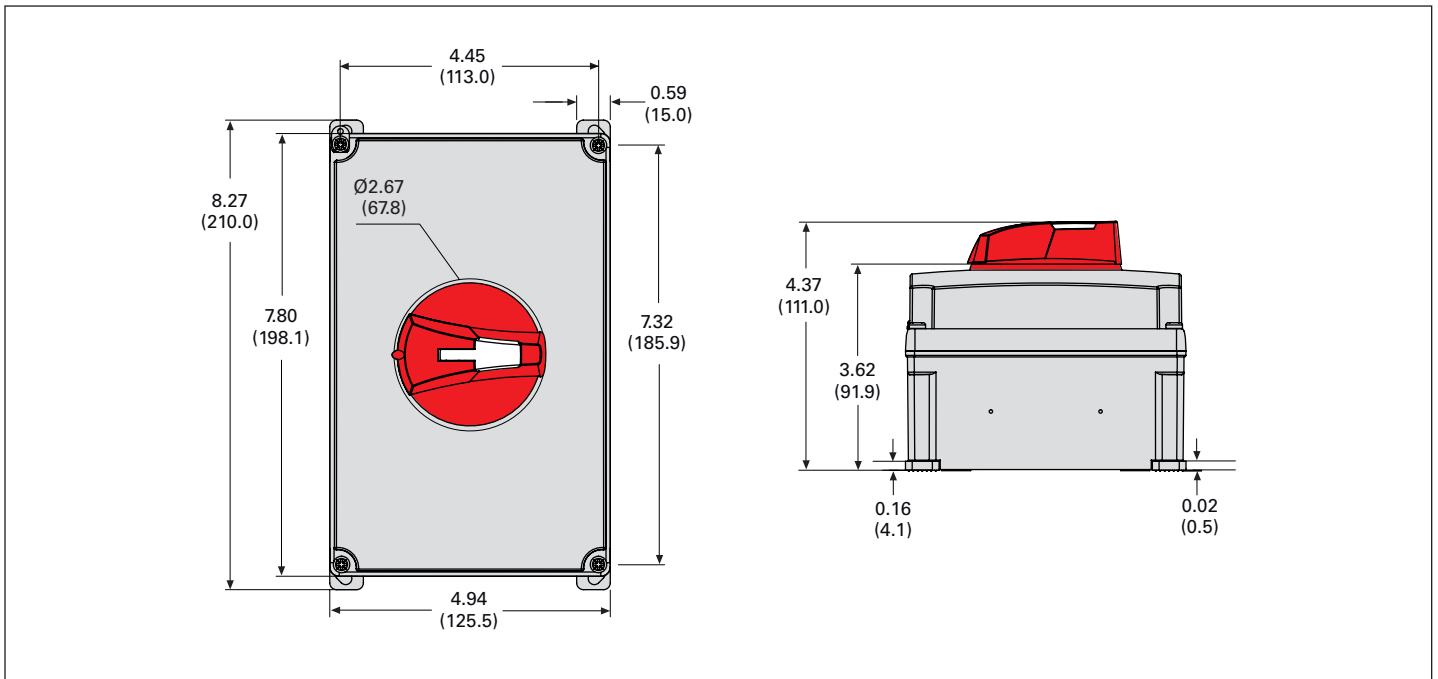

Figure 28.1-23. NEMA Type 4X—Polycarbonate (60 A)

## Maximum Horsepower Ratings

**Table 28.1-25. General-Duty, Fusible and Non-Fusible, 120 V with Time Delay Fuses**

Ampere Rating	Single-Phase AC	Three-Phase AC
30	2	3
60	3	7-1/2

**Table 28.1-26. General-Duty, Fusible and Non-Fusible, 240 V with Time Delay Fuses**

Ampere Rating	Single-Phase AC	Three-Phase AC
30	3	7-1/2
60	10	15
100	15	30
200	15	60
400	—	125
600	—	200

**Table 28.1-27. Heavy-Duty, Non-Fusible, 120 V**

Ampere Rating	Single-Phase AC	Three-Phase AC
30	2	5
60	3	10

**Table 28.1-28. Heavy-Duty, Fusible, 240 V with Time Delay Fuses ①**

Ampere Rating	Single-Phase AC	Three-Phase AC
30	3	7-1/2
60	10	15
100	15	30
200	15	60
400	—	125
600	—	200
800	—	250

① Data applicable to heavy-duty, enhanced visible blade and heavy-duty surge switches.

**Table 28.1-29. Heavy-Duty, Fusible, 480 V with Time Delay Fuses ②**

Ampere Rating	Single-Phase AC	Three-Phase AC
30	7-1/2	15
60	20	30
100	30	60
200	50	125
400	—	250
600	—	400
800	—	500

② Data applicable to heavy-duty, enhanced visible blade and heavy-duty surge switches.

**Table 28.1-30. Heavy-Duty, Fusible, 600 V with Time Delay Fuses ③**

Ampere Rating	Single-Phase AC	Three-Phase AC
30	10	20
60	25	50
100	40	75
200	50	150
400	—	350
600	—	500
800	—	500

③ Data applicable to heavy-duty, enhanced visible blade and heavy-duty surge switches.

**Table 28.1-31. Heavy-Duty, Non-Fusible, 240 V ④**

Ampere Rating	Single-Phase AC	Three-Phase AC
30	3	10
60	10	20
100	20	40
200	15	60
400	—	125
600	—	200
800	—	—

④ Data applicable to heavy-duty, enhanced visible blade and heavy-duty surge switches.

**Table 28.1-32. Heavy-Duty, Non-Fusible, 480 V ⑤**

Ampere Rating	Single-Phase AC	Three-Phase AC
30	7-1/2	20
60	20	50
100	40	75
200	50	125
400	—	250
600	—	400
800	—	500

⑤ Data applicable to heavy-duty, enhanced visible blade and heavy-duty surge switches.

**Table 28.1-33. Heavy-Duty, Non-Fusible, 600 V ⑥**

Ampere Rating	Single-Phase AC	Three-Phase AC
30	10	30
60	25	60
100	50	100
200	50	150
400	—	350
600	—	500
800	—	500

⑥ Data applicable to heavy-duty, enhanced visible blade and heavy-duty surge switches.

**Table 28.1-34. Double Throw, Fusible, 240 V with Time Delay Fuses**

Ampere Rating	Single-Phase AC	Three-Phase AC
30	3	7-1/2
60	10	15
100	15	30
200	15	60
400	—	125
600 ⑦	—	50

⑦ Only available for use with fast acting fuses. Standard hp rating is shown.

**Table 28.1-35. Double Throw, Fusible, 480 V with Time Delay Fuses**

Ampere Rating	Single-Phase AC	Three-Phase AC
30	7-1/2	15
60	20	30
100	30	60
200	50	125
400	—	250

**Note:** Ratings are based on three-pole designs.

**Table 28.1-36. Double-Throw, Fusible, 600 V with Time Delay Fuses**

Ampere Rating	Single-Phase AC	Three-Phase AC
30	10	20
60	25	50
100	40	75
200	50	150
400	—	350

**Table 28.1-37. Double-Throw, Non-Fusible, 240 V**

Ampere Rating	Single-Phase AC	Three-Phase AC
30	3	10
60	10	20
100	20	40
200	15	60
400	—	125
600	—	125
800	—	125

**Table 28.1-38. Double-Throw, Non-Fusible, 480 V**

Ampere Rating	Single-Phase AC	Three-Phase AC
30	7-1/2	20
60	20	50
100	40	75
200	50	125
400	—	250
600	—	250
800	—	250

**Table 28.1-39. Double-Throw, Non-Fusible, 600 V**

Ampere Rating	Single-Phase AC	Three-Phase AC
30	10	30
60	25	60
100	50	100
200	50	150
400	—	350
600	—	350
800	—	350

**Table 28.1-40. Heavy-Duty, Non-Fusible, 480 V, 600 V Types 7 and 9**

Ampere Rating	Three-Phase, 480V AC	Three-Phase, 600V AC
30	20	20
60	40	50
100	75	75
200	125	150

**Table 28.1-41. Heavy-Duty, Fusible, 480 V, 600 V Types 7 and 9 with Time Delay Fuses**

Ampere Rating	Three-Phase, 480V AC	Three-Phase, 600V AC
30	15	20
60	30	50
100	60	75
200	125	150

**Note:** Ratings are based on three-pole designs.

## Short-Circuit Ratings

### General-Duty

**Table 28.1-42. Short-Circuit Ratings Using Class “R,” “J” or “T” Fusing where Applicable**

Ampere Rating	Short-Circuit Ratings (Amperes)	
	Type 1	Type 3R
30	100 k at 240 V	100 k at 240 V
60	100 k at 240 V	100 k at 240 V
100	100 k at 240 V	100 k at 240 V
200	100 k at 240 V	100 k at 240 V
400	100 k at 250 V	100 k at 250 V
600	100 k at 250 V	100 k at 250 V

**Note:** Class “H” fuse clips supplied as standard for 30–600 A. Rated at 10,000 rms symmetrical when using Class “H” fuses.

### Heavy-Duty

**Table 28.1-43. Short-Circuit Ratings Using Class “R,” “J” or “T” Fusing where Applicable**

Ampere Rating	Short-Circuit Ratings (Amperes)			
	Type 1	Type 3R	Type 12	Type 4 and 4X
30	200 k at 600 V	200 k at 600 V	200 k at 600 V	200 k at 600 V
60	200 k at 600 V	200 k at 600 V	200 k at 600 V	200 k at 600 V
100	200 k at 480 V 100 k at 600 V	200 k at 480 V 100 k at 600 V	200 k at 600 V	200 k at 600 V
200	200 k at 600 V	200 k at 600 V	200 k at 600 V	200 k at 600 V
400	200 k at 480 V 100 k at 600 V	200 k at 480 V 100 k at 600 V	200 k at 480 V 100 k at 600 V	200 k at 480 V 100 k at 600 V
600	200 k at 480 V 100 k at 600 V	200 k at 480 V 100 k at 600 V	200 k at 480 V 100 k at 600 V	200 k at 480 V 100 k at 600 V
800 ①	200 k at 480 V 100 k at 600 V	200 k at 480 V 100 k at 600 V	200 k at 480 V 100 k at 600 V	200 k at 480 V 100 k at 600 V
1200 ①	200 k at 600 V	200 k at 600 V	200 k at 600 V	200 k at 600 V

① Class “L” fuse connectors supplied as standard for 800 A and 1200 A.

**Note:** Class “H” fuse clips supplied as standard for 30–600 A. Rated at 10,000 A rms symmetrical when using Class “H” fuses.

### Double Throw

**Table 28.1-44. Short-Circuit Ratings Using Class “R,” “J” or “T” Fusing where Applicable**

Ampere Rating	Short-Circuit Ratings (Amperes) (600V)			
	Type 1	Type 3R	Type 12	Type 4 and 4X
30	100 k	100 k	100 k	100 k
60	100 k	100 k	100 k	100 k
100	100 k	100 k	100 k	100 k
200	100 k	100 k	100 k	100 k
400	100 k	100 k	100 k	100 k
600	100 k	100 k	100 k	100 k
800	100 k	100 k	—	—
1200	100 k	100 k	—	—

**Note:** Class “H” fuse clips supplied as standard for 30–600 A, except Class “T” for 400 A at 600 V and 600 A at 240 V. Rated at 10,000 A rms symmetrical when using Class “H” fuses.

**Note:** Class “L” fuse connectors supplied as standard for 800 A and 1200 A.

**Note:** Safety switch short-circuit ratings are applicable to AC only.

**Note:** Safety switch  $I^2t$  and  $I_p$  values are identical to UL maximum acceptable  $I^2t$  and  $I_p$  values for the corresponding class fuse.

**Note:** Table 28.1-44 is not applicable to the compact design shown in Eaton’s Volume 2—Commercial Distribution, CA08100003E, Tab 8, Section 8.1. The compact design is suitable for use on a circuit capable of delivering not more than 10,000 rms symmetrical amperes.

### Shunt Trip Safety Switch

**Table 28.1-45. Short-Circuit Ratings Using Class “R,” “J/L” or “T” Fusing ②**

Ampere Rating	480 V	600 V
30	200 kAIC	200 kAIC
60	200 kAIC	200 kAIC
100	200 kAIC	200 kAIC
200	200 kAIC	100 kAIC
400	200 kAIC	100 kAIC
600	200 kAIC	100 kAIC
800	200 kAIC	200 kAIC

② Non-fusible values are based on combination rating with upstream device (see TD00801005E).

### Short-Circuit Ratings of Non-Fusible Switches

The UL listed short-circuit ratings for Eaton’s non-fusible switches are based on the switches being properly protected by overcurrent protective devices. For applications that require a UL listed short-circuit rating of 10,000 rms symmetrical amperes or less, an Eaton non-fusible switch must be properly protected by any overcurrent protective device rated no greater than the ampere rating of the switch. For applications that require a UL listed short-circuit rating of greater than 10,000 rms symmetrical amperes, an Eaton non-fusible switch must be properly protected by the appropriate class and size fusing noted in the applicable table on this page. Otherwise, this non-fusible switch must be replaced with an Eaton fusible switch that uses the appropriate fusing required. Molded case circuit breaker protection of non-fusible Eaton switches for applications that require a short-circuit rating of greater than 10,000 rms symmetrical amperes has been evaluated and is summarized below. Refer to the reference tables for typical Eaton fusible switch UL listed short-circuit ratings.

**Table 28.1-46. UL Recognized Safety Switch/Circuit Breaker Series-Connected Ratings**

Safety Switch Ampere Rating	Maximum System Voltage AC	Circuit Breaker Maximum Short Circuit Rating (rms Symmetrical)	Circuit Breaker Frame(s)
30 and 60	600	25,000	FDC, HFD, HFDE, EGH
		18,000	FD, EGE
100	600	14,000	FDB
		25,000	FDC, HFD, HFDE, EGH
		18,000	FD, EGE
200	600	14,000	FDB
		35,000	EGH, EGS
		25,000	FDC, HFD, HFDE, HJD, JGH
		18,000	FD, JD, JGE
480	65,000	14,000	FDB
		65,000	HFD, HFDE, HJD, JGH

Fuse Dimensions

**Class T**

T-Tron™ Fuses

JJN (300V)

JJS (600V)

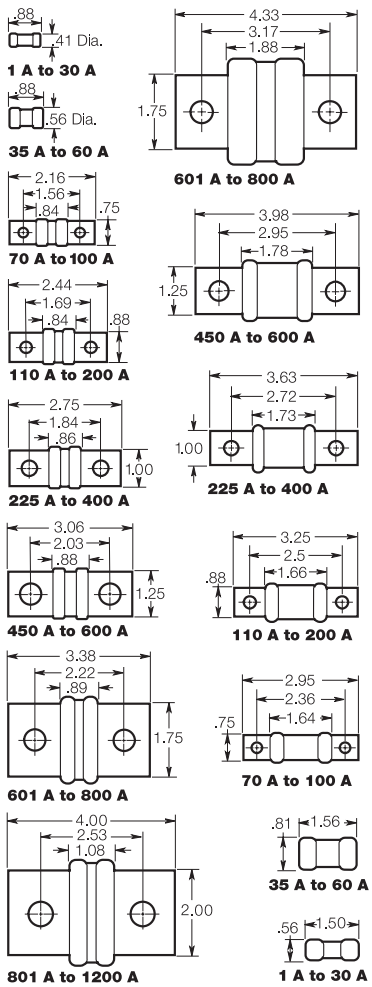

**Class J**

Low-Peak® and Limitron® Fuses  
LPJ & JKS (600V)

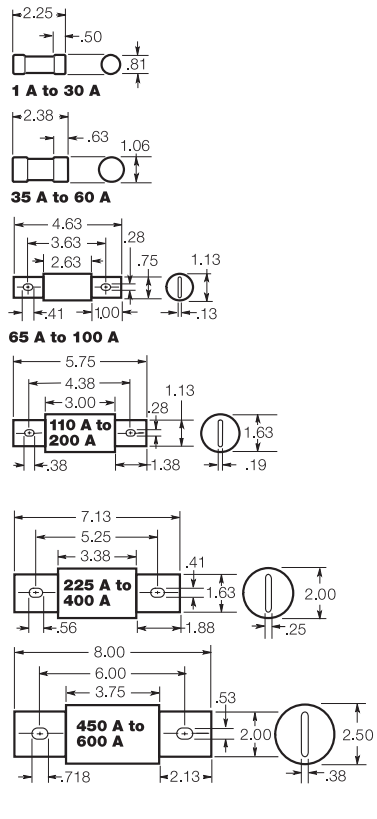

**Class RK5 and RK1**

Fusetron®, Low-Peak and  
Limitron Fuses (250 and 600V)

FRN-R and FRS-R; LPN-RK  
and LPS-RK; KTN-R and KTS-R  
Basic dimensions are same as Class H  
(formerly NEC) ONE-TIME (NON and NOS)  
and SUPERLAG Renewable RES and  
REN fuses.

**Note:** These fuses can be used to replace  
existing Class H, RK1 and RK5 fuses relating  
to dimensional compatibility.

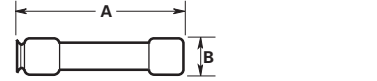

Ampere	250V		600V	
	A	B	A	B
1/10-30	2.00	0.56	5.00	0.81
35-60	3.00	0.81	5.50	1.06

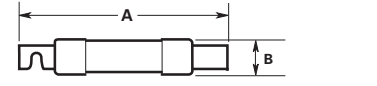

**Fusetron and Limitron**

Ampere	250V		600V	
	A	B	A	B
70-100	5.88	1.06	7.88	1.34
110-200	7.13	1.56	9.63	1.84
225-400	8.63	2.06	11.63	2.59
450-600	10.38	2.59	13.38	3.13

**Low-Peak**

Ampere	250V		600V	
	A	B	A	B
70-100	5.88	1.16	7.88	1.16
110-200	7.13	1.66	9.63	1.66
225-400	8.63	2.38	11.63	2.38
450-600	10.38	2.88	13.38	2.88

**Class L Low-Peak and Limitron Fuses**

KRP-C, KTU & KLU (601-4000A) (600V)

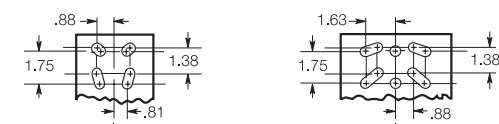

**Note:** KRP-CL (150-600A) fuses  
have same dimensions as 601-800A  
case size. KTU (200-600A) have  
same dimensions, except tube  
3-inch lgth. x 2-inch dia.; terminal  
1.63-inch width x 1.25-inch thick.

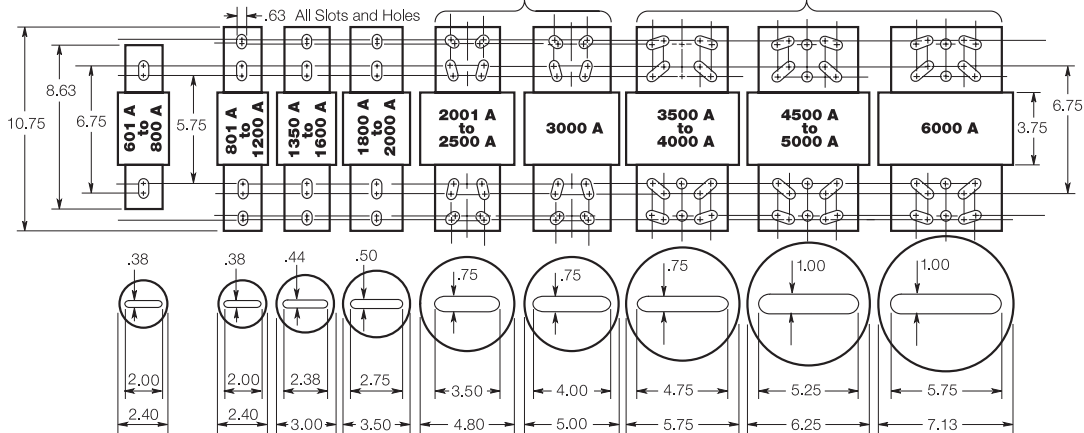

Figure 28.1-24. Typical Fuse Dimensions in Inches

**Note:** For typical fuse dimensions in millimeters, see Figure 28.1-25 on Page 28.1-27.

**Class T**

**T-Tron Fuses  
JJN (300V)**

1 A to 30 A  
35 A to 60 A

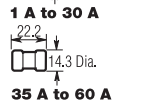

70 A to 100 A

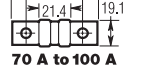

110 A to 200 A

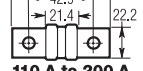

225 A to 400 A

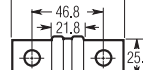

450 A to 600 A

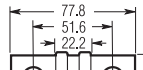

601 A to 800 A

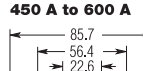

801 A to 1200 A



**JJS (600V)**

601 A to 800 A

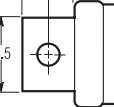

450 A to 600 A

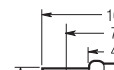

225 A to 400 A



110 A to 200 A

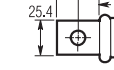

70 A to 100 A



35 A to 60 A

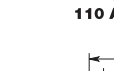

1 A to 30 A

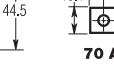

**Class J**

**Low-Peak and Limitron Fuses  
LPJ and JKS (600V)**

1 A to 30 A

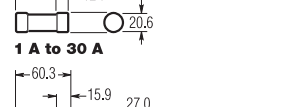

35 A to 60 A



65 A to 100 A

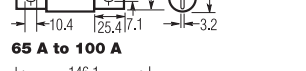

110 A to 200 A

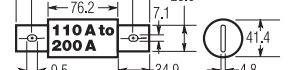

225 A to 400 A

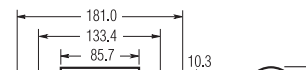

450 A to 600 A

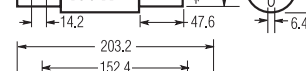

**Class RK5 and RK1**

**Fusetron, Low-Peak and  
Limitron Fuses (250 and 600V)**

FRN-R and FRS-R; LPN-RK and LPS-RK; KTN-R and KTS-R  
Basic dimensions are same as Class H (formerly NEC) ONE-TIME (NON and NOS) and SUPERLAG Renewable RES and REN fuses.

**Note:** These fuses can be used to replace existing Class H, RK1 and RK5 fuses relating to dimensional compatibility.

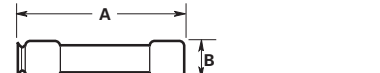

Ampere	250V		600V	
	A	B	A	B
1/10-30	50.8	14.3	127.0	20.6
35-60	76.2	20.6	139.7	27.0

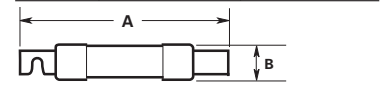

**Fusetron and Limitron**

Ampere	250V		600V	
	A	B	A	B
70-100	149.2	26.9	200.0	34.0
110-200	181.0	39.6	244.5	46.7
225-400	219.1	52.3	295.3	65.8
450-600	263.5	65.8	339.7	79.5

**Low-Peak**

Ampere	250V		600V	
	A	B	A	B
70-100	149.2	29.5	200.0	29.5
110-200	181.0	42.2	244.5	42.2
225-400	219.1	60.5	295.3	60.5
450-600	263.5	73.2	339.7	73.2

**Class L Low-Peak and Limitron Fuses**

**KRP-C, KTU and KLU (601-4000A) (600V)**

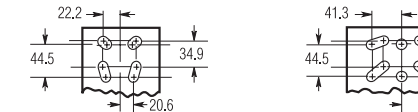

**Note:** KRP-CL (150-600A) fuses have same dimensions as 601-800A case size. KTU (200-600A) have same dimensions, except tube 76.2 mm lgth. x 50.8 mm dia.; terminal 41.3 mm width x 31.8 mm thick.

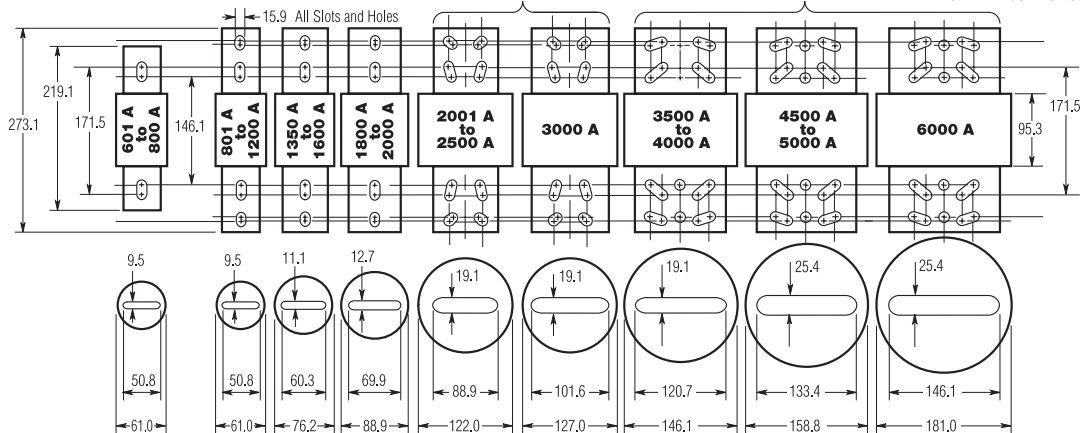

**Figure 28.1-25. Typical Fuse Dimensions in Millimeters**

**Note:** For typical fuse dimensions in inches, see Figure 28.1-24 on Page 28.1-26.

Table 28.1-47. Safety Switch Catalog Numbering System—General Duty

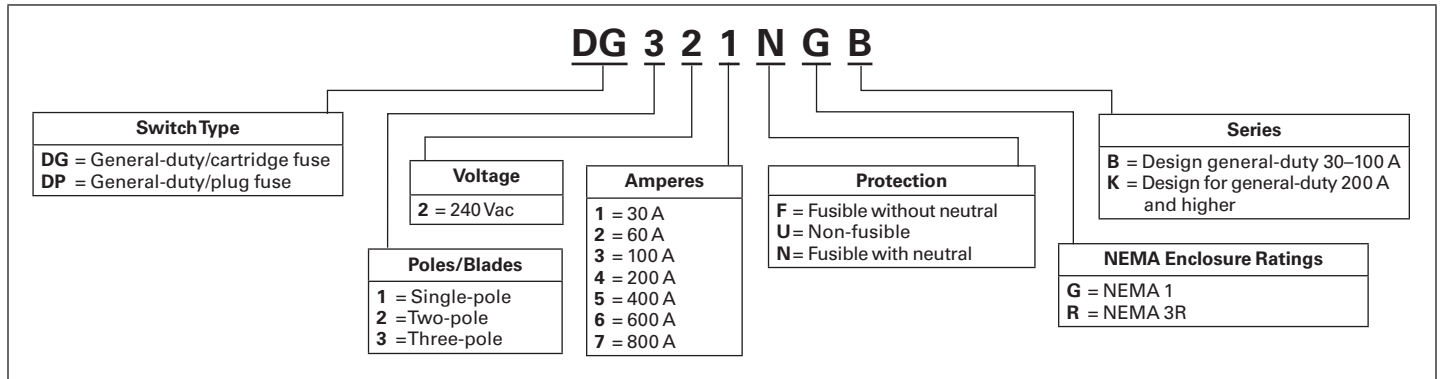
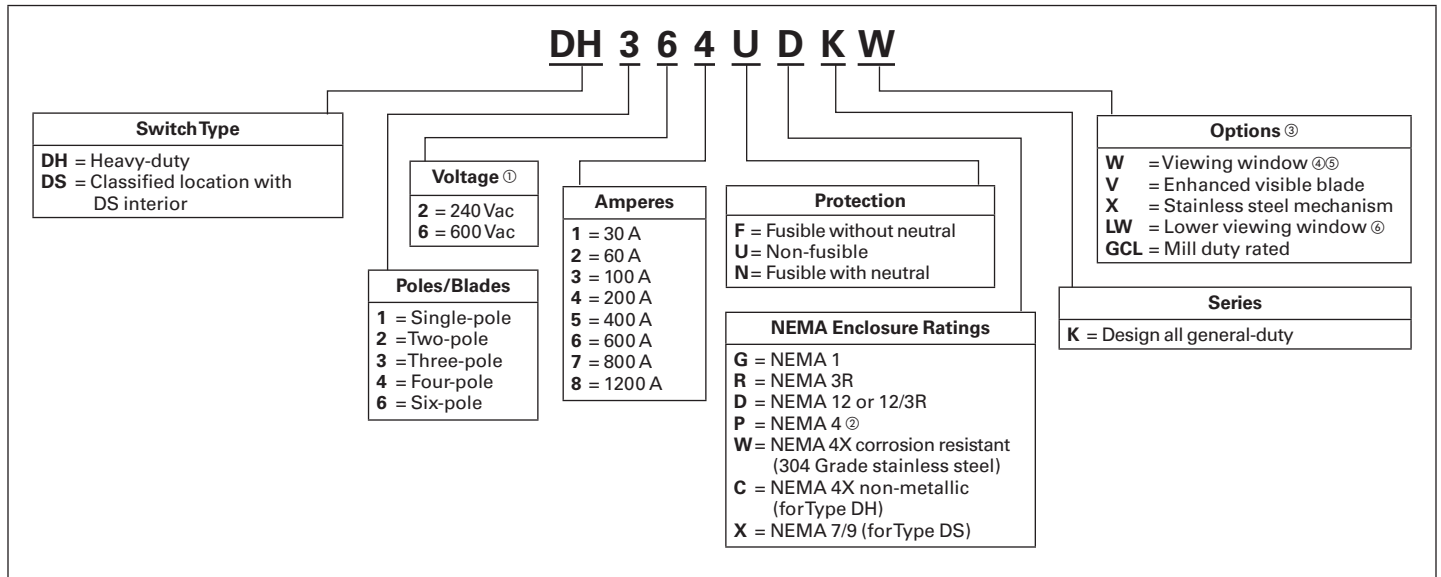

Table 28.1-48. Safety Switch Catalog Numbering System—Heavy Duty



- ① For DC ratings, check individual switch ratings.
- ② Only available for 400 A and higher safety switches.
- ③ See Modifications-Flex Center for additional available options.
- ④ All window switches feature enhanced visible blade design as standard.
- ⑤ Only available in NEMA 12/3R and NEMA 4X enclosures.
- ⑥ Only available in 200 to 1200 A NEMA 12/3R and NEMA 4X enclosures.

**Note:** These tables are intended for use in breaking down existing catalog numbers. They are not intended for building new catalog numbers. A factory-installed ground lug is supplied on all safety switches.



Table 28.1-49. Heavy-Duty Safety Switch with Surge Protection Catalog Numbering System

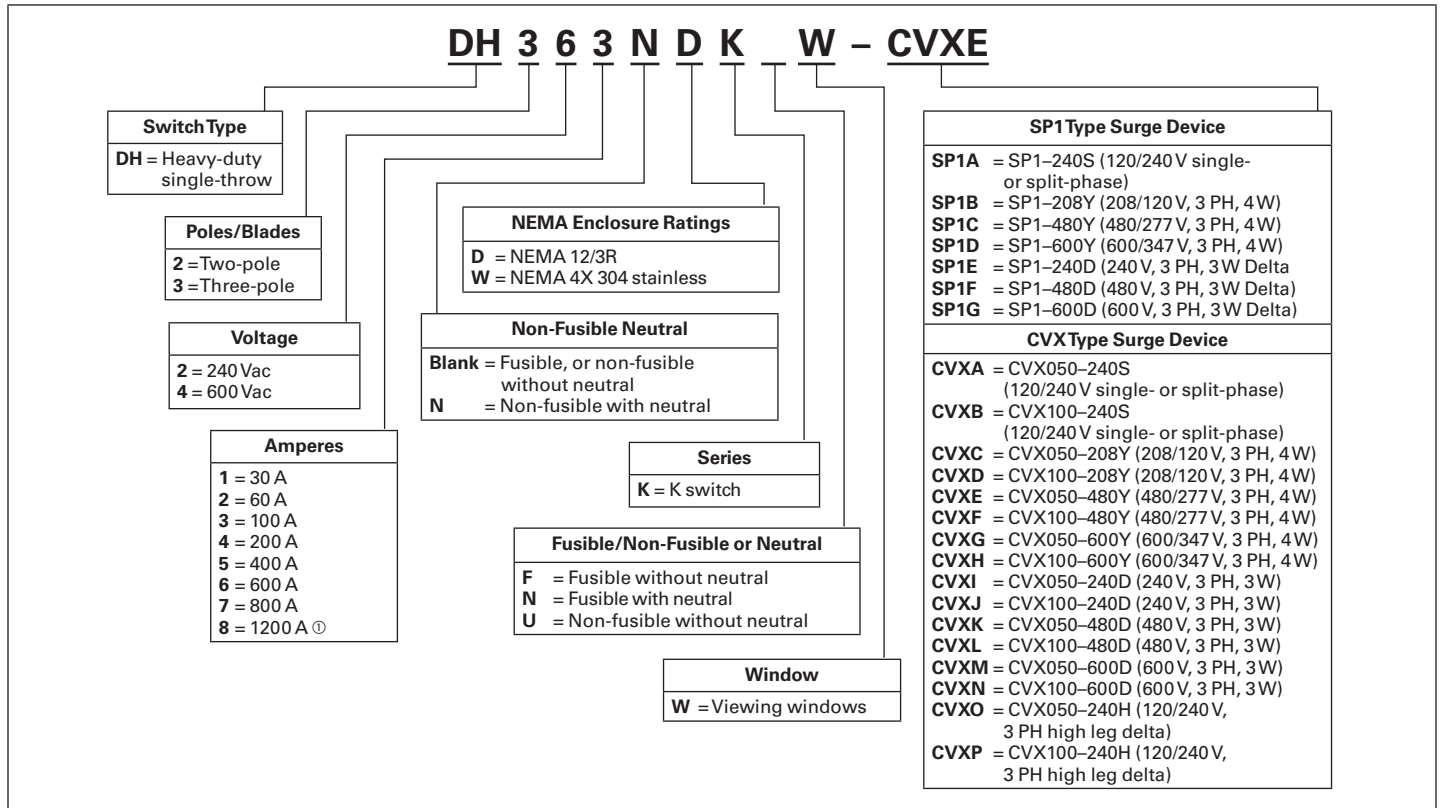

① Available with SP1 type surge device only.

**Note:** This table is intended for use in breaking down existing catalog numbers. It is not intended for building new catalog numbers.

Table 28.1-50. Auxiliary Power Heavy-Duty Safety Switch Catalog Numbering System

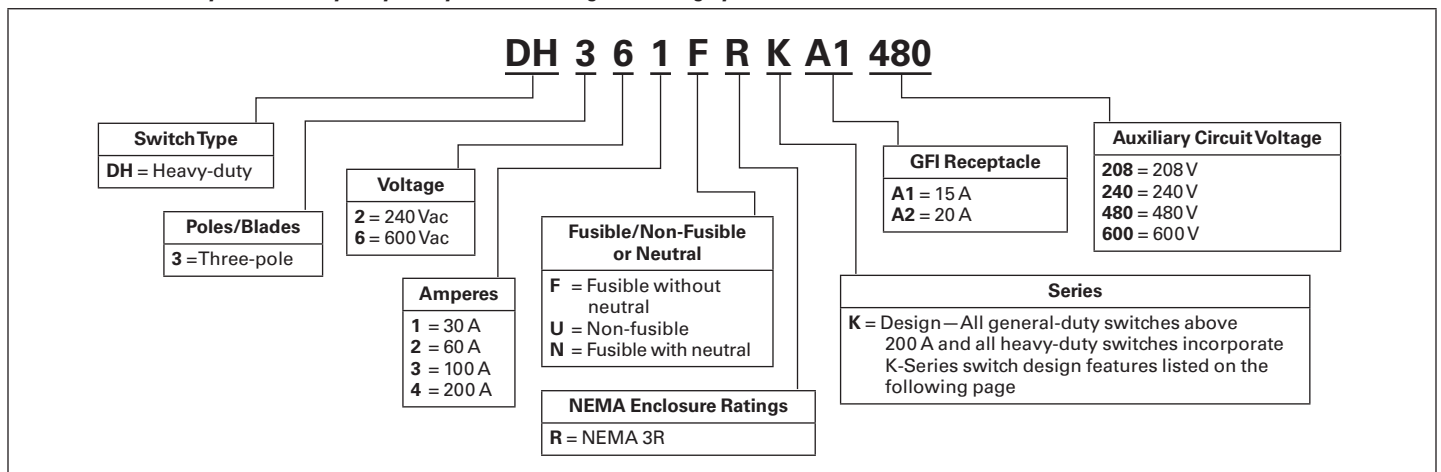
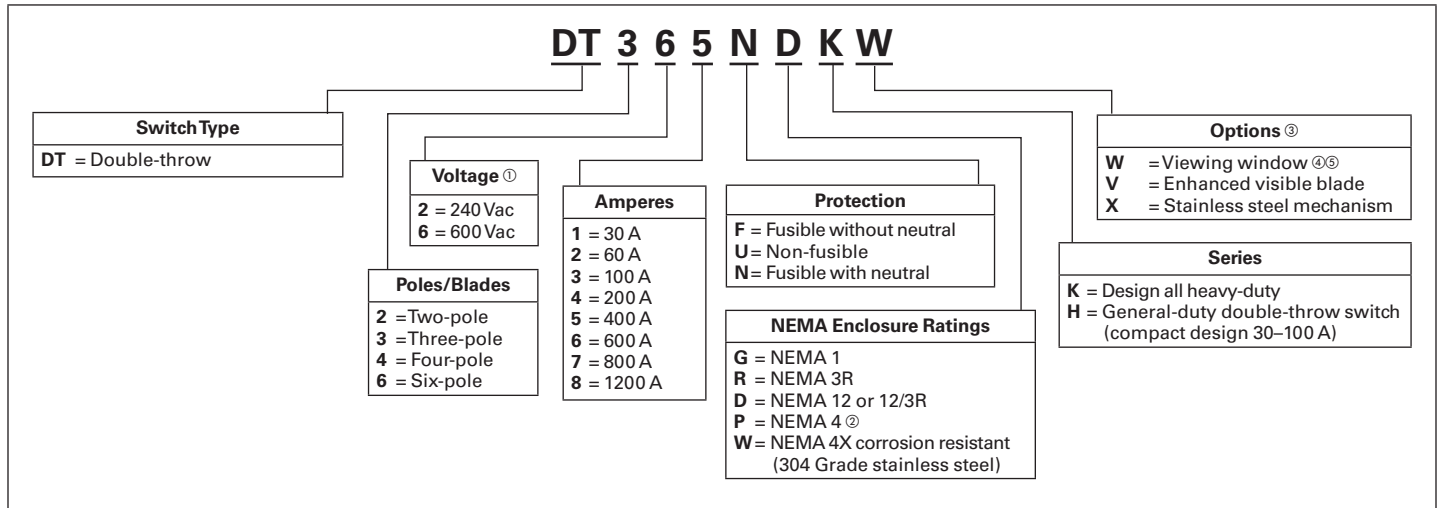

Table 28.1-51. Safety Switch Catalog Numbering System—Double Throw



- ① For DC ratings, check individual switch ratings.
- ② Only 22 available for 400 A and higher safety switches.
- ③ See Modifications-Flex Center for additional available options.
- ④ All window switches feature enhanced visible blade design as standard.
- ⑤ Only available in NEMA 12/3R and NEMA 4X enclosures.

**Note:** These tables are intended for use in breaking down existing catalog numbers. They are not intended for building new catalog numbers. A factory-installed ground lug is supplied on all safety switches.

Table 28.1-52. Shunt Trip Safety Switch Catalog Numbering System

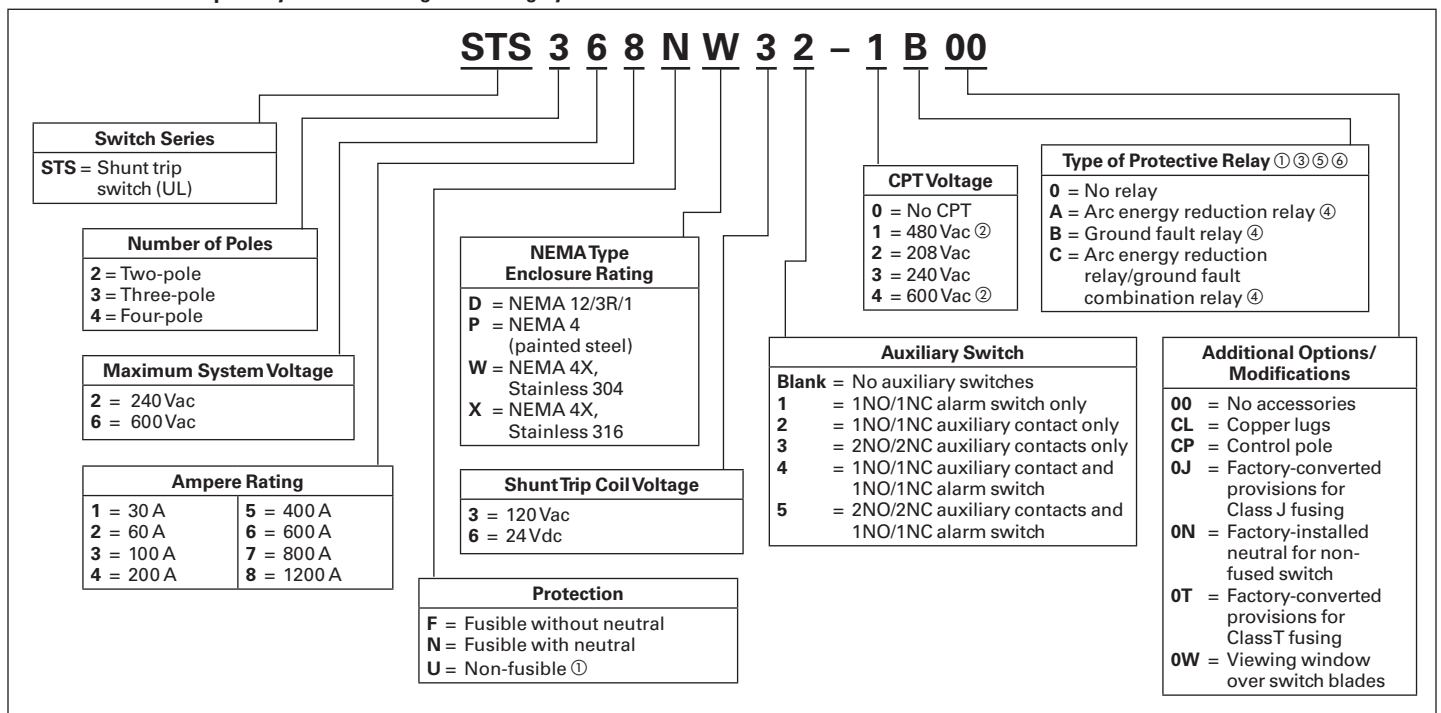

- ① Relays can only be used with fusible switches.
- ② Available for 600 Vac switches only.
- ③ Shunt trip safety switch with relay protection must use 120 Vac coils.
- ④ Available for 400–1200 A fusible switches only.
- ⑤ Only one relay option allowed.
- ⑥ Relay viewing window standard with relay option.



The Eaton logo consists of the word "EATON" in a bold, blue, sans-serif font. The letter "O" is stylized as a white circle with a blue dot in the center, creating a visual effect of a power symbol or a stylized letter.

*Powering Business Worldwide*

### Catalog Number Selection

#### General-Duty

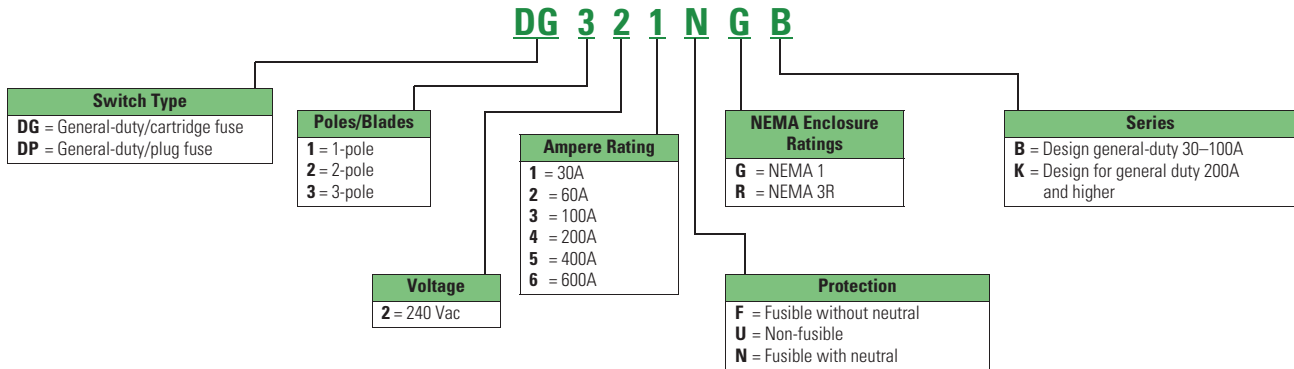

#### Heavy-Duty

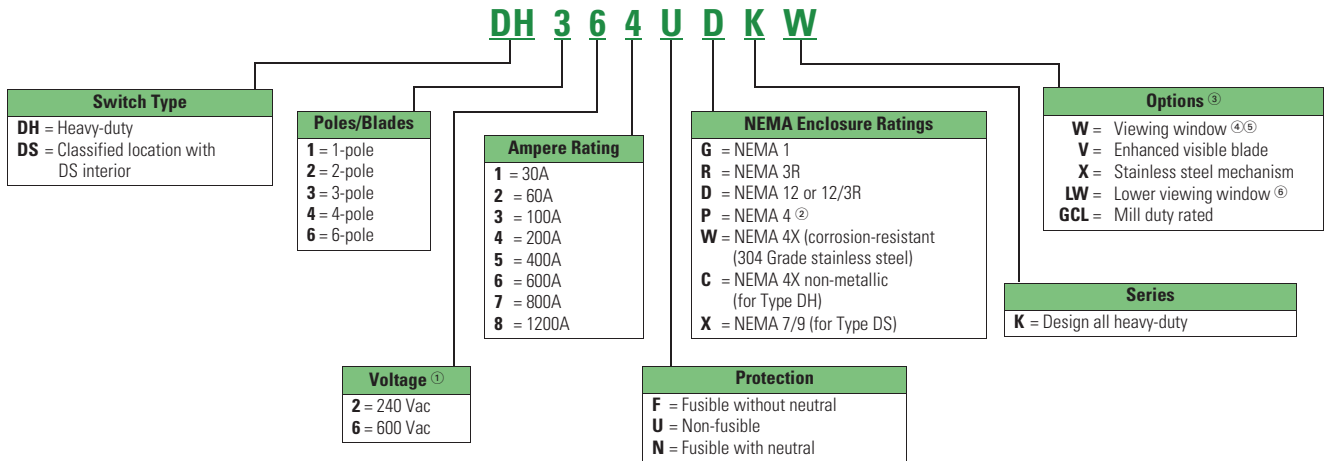

#### Notes

- ① For DC ratings, check individual switch ratings.
- ② Only available for 400A and higher safety switches.
- ③ See Modifications-Flex Center for additional available options.
- ④ All window switches feature enhanced visible blade design as standard.
- ⑤ Only available in NEMA 12/3R and NEMA 4X enclosures.
- ⑥ Only available in 200 to 1200A NEMA 12/3R and NEMA 4X enclosures.

**These tables are intended for use in breaking down existing catalog numbers. They are not intended for building new catalog numbers.**

A factory-installed ground lug is supplied in all heavy-duty safety switches.

#### Double-Throw

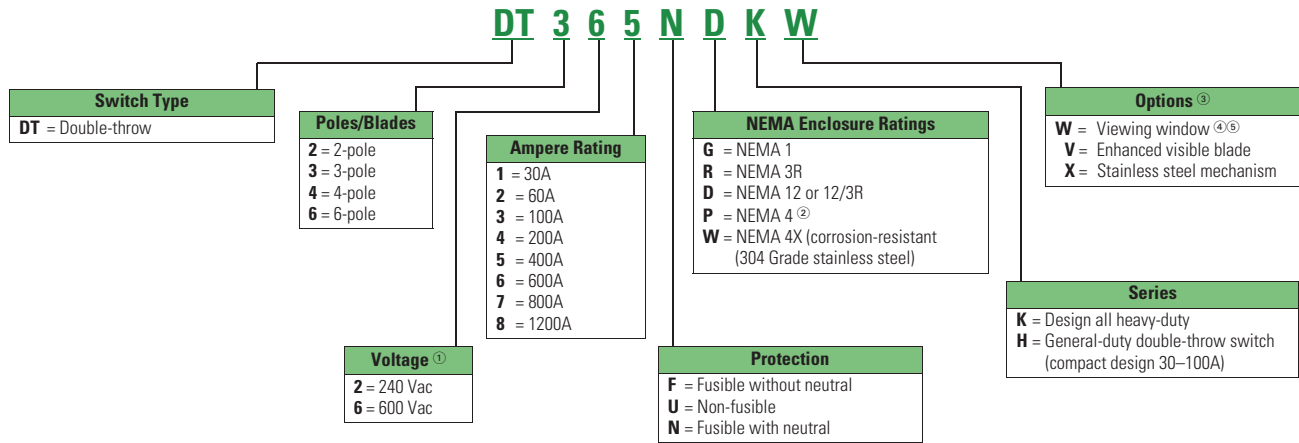

#### Notes

- ① For DC ratings, check individual switch ratings.
- ② Only available for 400A and higher safety switches.
- ③ See Modifications-Flex Center for additional available options.
- ④ All window switches feature enhanced visible blade design as standard.
- ⑤ Only available in NEMA 12/3R and NEMA 4X enclosures.

**These tables are intended for use in breaking down existing catalog numbers. They are not intended for building new catalog numbers.**

A factory-installed ground lug is supplied in all heavy-duty safety switches.

The Eaton logo consists of the word "EATON" in a bold, blue, sans-serif font. The letter "O" is stylized as a white circle with a blue dot in the center, creating a visual effect of a power symbol or a stylized letter.

*Powering Business Worldwide*

## Heavy-Duty Safety Switch

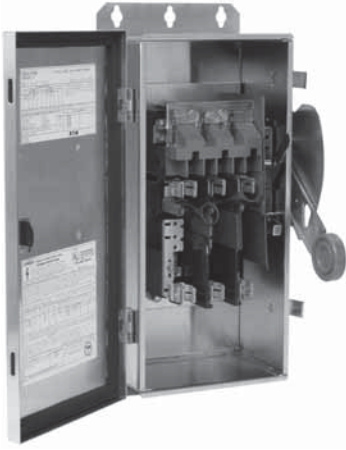

## Heavy-Duty

### Product Description

- 30–1200A
- 600 Vac, 600 Vdc maximum
- Horsepower rated
- Fusible and non-fusible switches are 100% load break and 100% load make rated
- The continuous load current of fusible switches is not to exceed 80% of the rating of fuses employed in other than motor circuits. Non-fusible switches are 100% fully rated
- Suitable for service entrance applications unless otherwise noted
- For factory modifications, refer to **Page V2-T1-15**

### Application Description

For heavy commercial and industrial applications where reliable performance and service continuity are critical.

For the toughest heavy commercial and industrial applications, refer to **Page V2-T1-77** for catalog information on our mill-duty safety switch.

316 Grade stainless steel is often a desirable choice for wastewater treatment plants and petrochemical facilities.

### Features, Benefits and Functions

- Deionizing arc chutes; arc chutes confine and suppress the arcs produced by opening contacts under load
- Mechanically interlocked cover to prevent easy access when the switch is in the ON position
- Clearly visible palm fitting red handle
- Premium 316-Grade stainless steel enclosures offer better corrosion resistance in the presence of most chemicals, salts and acids, and is more resistant to marine atmospheres
- Visible double-break quick-make, quick-break blades
- Visible ON/OFF indication

- 30–1200A NEMA 12 designs convertible to NEMA 3R by opening factory-installed drain hole
- Tri-lingual nameplates

### Standards and Certifications

- UL listed File No. E5239
- Meets UL 98 for enclosed switches and NEMA Std. KS-1



### Seismic Qualifications

- Heavy-duty switches exceed the requirements of Uniform Building Code (UBC) and California Code Title 24 OSP-0011-10, OSP-0012-10





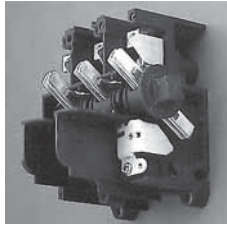

**Visible Double-Break Rotary Blade Mechanism**

- Two points of contact provide a positive open and close, easier operation, and also help prevent contact burning for longer contact life

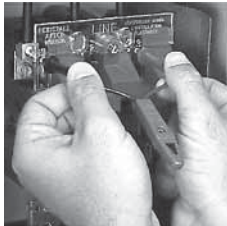

**Clear Line Shield**

- Protects against accidental contact with energized parts. Probe holes enable the user to test if the line side is energized without removing the shield. Not typically provided on general-duty switches, but available as a field kit or factory installed

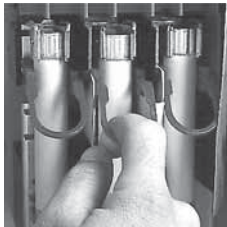

**Built-In Fuse Pullers (NEMA 12 and 4X 30–200A Only)**

- Provide easy removal of fuses



**Clearly Visible Handle**

- The position (ON or OFF) can be clearly seen from a distance and the length provides for easy operation



**Triple Padlocking Capability**

- Personnel safety feature because the large hasp can accommodate up to three 3/8-inch (9.5 mm) shank locks



**Additional Locking Capability**

- Cabinet door can be further padlocked at the top and bottom as applicable

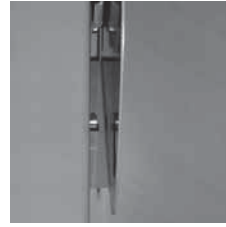

**Interlocking Mechanism**

- Door cannot be opened when the handle is in the ON position. Front and side operable defeater mechanism provides for user access when necessary on single-throw switches



**Tangential Knockouts**

- An ample number are provided on the top, bottom and sides of both NEMA Types 1 and 3R enclosures through 200A

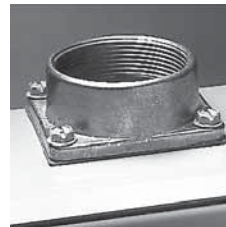

**Bolt-On Hub Kits**

- For switches in a NEMA Type 3R, 30–200A. Use a Myers type hub for all others

## Technical Data and Specifications

## Standard Lug Capacities

Description	Minimum Wire Size	Maximum Wire Size	Wire Type
30A DP	#14	#10	CU
	#12	#10	AL
30A DG	#14	#6	CU/AL
30A DH, DT	#14	#2	CU/AL
60A DG	#14	#1/0	CU/AL
60A DH, DT	#14	#2	CU/AL
100A DG ①	#14	#1/0	CU/AL
100A DH, DT	#14	#1/0	CU/AL
200A DG, DT	#6	250 kcmil	CU/AL
200A DH Type 1 and 3R	#6	250 kcmil	CU/AL
200A DH Type 4X and 12	#6	300 kcmil	CU/AL
400A DG, DH, DT ②	(2) #1/0	(2) 300 kcmil	CU/AL or ③
	(1) #1/0	(1) 750 kcmil	CU/AL
600A DG, DH	(1) #2	(1) 600 kcmil	CU/AL and ④
	(1) #1/0	(1) 750 kcmil	CU/AL
600A non-fusible DT	(2) 250	(2) 500 kcmil	CU/AL
800A DH	(4) #1/0	(4) 750 kcmil	CU/AL
600A fusible DT, 800A DT	(3) #250	(3) 500 kcmil	CU/AL
1200A DH, DT	(4) #1/0	(4) 750 kcmil	CU/AL
<b>Copper-Bodied Lugs ⑤</b>			
30A CU	#14	#6	CU
60A CU	#14	#4	CU
100A CU	#6	#1/0	CU
200A CU	#6	250 kcmil	CU
400A CU Type 4, 4X, and 12	#1/0	500 kcmil	CU
600-800A CU Type 4, 4X and 12	(2) #1/0	(2) 500 kcmil	CU

**Notes**

- ① The maximum size aluminum or copper-clad wire allowable for applications where the conductor enters or leaves the enclosure through the wall opposite its terminal is #1 gauge.
- ② Applicable to DG/DH non-fused NEMA 1 and 3R only. The maximum size wire allowable for applications where the conductor enters or leaves the enclosure through the wall opposite its terminal is 250 kcmil.
- ③ Single barrel lug that accepts one or two cables per phase as detailed above.
- ④ Double barrel lug that accepts 2 cables per phase as detailed above.
- ⑤ No Copper-Bodied Lugs are available for 1200A switches. No Copper-Bodied Lugs are available for larger than 500 kcmil cables. No Copper-Bodied Lugs are available for 400–800A NEMA 1 or NEMA 3R switches.







Although certain lug capacities are larger than required, only minimum wire bending space is provided per the requirements noted in NEC®. A factory-installed ground lug is supplied in all heavy-duty safety switches.

The Eaton logo consists of the word "EATON" in a bold, blue, sans-serif font. The letter "O" is stylized as a white circle with a blue dot in the center, creating a visual effect of a power symbol or a stylized letter.

*Powering Business Worldwide*

## Options and Accessories

## Safety Switches

	Description	Catalog Number
	<b>Neutral Kits</b>	
	30A DG	<b>DG030NB</b>
	60–100A DG	<b>DG100NB</b>
	200A DG, DH (NEMA 1, 3R enclosures)	<b>DG200NK</b>
	30–60A DH	<b>DH030NK</b>
	100A DH	<b>DH100NK</b>
	200A DH (NEMA 4X, 12 enclosures)	<b>DH200NK</b>
	400A DG, DH	<b>DS400NK</b>
	600A DG, DH	<b>DS600NK</b>
	400A fusible DT, 800–1200A DH	<b>DS800NK</b>
	30–100A DT	<b>DT100NK</b>
	200A DT	<b>DT200NK</b>
	400A non-fusible DT	<b>DT400NK</b>
	600A non-fusible DT	<b>DT600NK</b>
	600A fusible DT, 800A DT	<b>DT800NK</b>
1200A DT	<b>DT1200NK</b>	
	<b>Ground Lug Kits</b> Factory-installed ground lug is supplied in all safety switches	
	30–100A DG	<b>DG030GB</b>
	30–100A DH, DT ①	<b>DS100GK</b>
	200A DG, DH, DT	<b>DS200GK</b>
	400–600A DG, 400–1200A DH, 400–1200A DT	<b>DS468GK</b>
	<b>Switching Neutral Bonding Kits</b> ②	
	30–100A DT, 3P, 4P non-fusible	<b>DT100BK</b>
	200A DT, 3P, 4P non-fusible	<b>DT200BK</b>
	400A DT, 3P, 4P non-fusible	<b>DT400BK</b>
	600A DT, 3P, 4P non-fusible	<b>DT600BK</b>
	800–1200A DT, 3P, 4P non-fusible	<b>DT800BK</b>
	<b>Control Pole Kit (For 2P, 3P Switches)</b>	<b>DS16CP</b>
	400–600A DG, 30–1200A DH, 30–1200A DT Multiple key options are included with the control pole kit. Standard keys provide late-make, early-break functionality. Flanged key provides same make, same break functionality.	
	<b>Auxiliary Contact Kits</b> Auxiliary contact kits are not field installable on shunt trip safety switches	
	All switches (except 30–100A DG) 1NO/1NC	<b>DS200EK1</b> ③
	All switches (except 30–100A DG) 2NO/2NC	<b>DS200EK2</b> ③
	NEMA 7/9 switches (30–100A) 1NO/1NC	<b>178C265G05</b>
	NEMA 7/9 switches (30–100A) 2NO/2NC	<b>178C265G06</b>
	<b>Copper Lug Kits</b>	
	30A DH, DT ④	<b>DS16CL</b>
	60A DH, DT ④	<b>DS26CL</b>
	100A DH, DT ④	<b>DS36CL</b>
	200A DH ④	<b>DS46CL</b>
	400A DH (NEMA 4, 4X, 12 enclosures) ⑤	<b>DS56CL</b>
	600–800A DH (NEMA 4, 4X, 12 enclosures) ⑤	<b>DS66CL</b>

## Safety Switches, continued

	Description	Catalog Number
	<b>Crimp Lug Pad Kit (NEMA 4, 4X, 12 Enclosures Only)</b>	
	400–600A DH ④	<b>DS56CK</b>
	800A DH ⑤	<b>DS76CK</b>
	400–800A neutral DH ②	<b>DS800CNK</b>
	<b>Fuse Puller Kits</b>	
	30A DH ④	<b>DS30FP</b>
	60A DH ④	<b>DS60FP</b>
	100A DH ④	<b>DS100FP</b>
	200A DH ④	<b>DS200FP</b>
	<b>"J" Fuse Adapter Kits</b> ⑥⑦	
	60A 240V DH ④	<b>DS22JK</b>
	60A DH, DT and receptacle switches ④	<b>DS26JK</b>
	400A 600V DT ⑧	<b>DT400JK</b>
	600A 240–600V DH, 600A DG ⑤	<b>DS600JK</b>
	<b>"R" Fuse Adapter Kits</b> ④	
	30A DG	<b>DG030RB</b>
	100A DG	<b>DG100RB</b>
	30A 240V DH, DT	<b>DS12FK</b>
	30A 600V DH, DT, 60A 240V DH, DT, 60A DG	<b>DS16FK</b>
	60A 600V DH, DT	<b>DS26FK</b>
	100A 240–600V DH, DT	<b>DS36FK</b>
	200A 240–600V DH, DT, 200A DG	<b>DS46FK</b>
	400A 240–600V DH, 240V DT, 400A DG	<b>DS56FK</b>
	600A 240–600V DH, DT, 600A DG	<b>DS66FK</b>
	<b>"T" Fuse Adapter Kits</b>	
	200A 240V DH ④	<b>DS426TK</b>
	200A 600V DH ④	<b>DS466TK</b>
	400A 240V DG, DH, DT ⑤	<b>DS526TK</b>
	400A 600V DH ⑤	<b>DS566TK</b>
	600A 240V DG, DH ⑤	<b>DS626TK</b>
	600A 600V DH ⑤	<b>DS666TK</b>
	600A 240V ⑤	<b>DT626TK</b>
	600A 600V ⑤	<b>DT666TK</b>
	800A 240V DH ⑤	<b>DS726TK</b>
800A 600V DH, DT ⑤	<b>DS766TK</b>	
	<b>Miscellaneous Kits</b>	
	Hookstick handle	<b>DH800HSH</b>
	Lubricating grease for safety switch blades and contacts (each kit contains three 30 cc tubes of lubricating grease)	<b>DSLUBEKIT</b>

## Notes

- ① Ground bar kit is not listed on device publications.
- ② Order one kit per switch.
- ③ For duty ratings, see table on following page.
- ④ Order one kit for three poles.
- ⑤ Order one kit for each pole.
- ⑥ 30A Class J available as factory option only.
- ⑦ If Class J fuse kit is not listed, then switch will accept Class J fusing by repositioning either fuse base or fuse clips. No drilling required.
- ⑧ Order one kit for six poles.

Accessories are not applicable to NEMA 7/9 switches unless indicated otherwise.

**Auxiliary Contact Rating****AC Pilot Duty Ratings**

Catalog Number	Description	Volts	Break (Amperes)	Make (Amperes)
DS200EK1	1NO-1NC	110	15.0	40.0
DS200EK1	1NO-1NC	220	10.0	20.0
DS200EK1	1NO-1NC	440	6.0	10.0
DS200EK1	1NO-1NC	600	5.0	8.0
DS200EK2	2NO/2NC	110	3.0	30.0
DS200EK2	2NO/2NC	220	1.5	15.0
DS200EK2	2NO/2NC	440	1.0	8.0
DS200EK2	2NO/2NC	600	0.8	6.0

**DC Pilot Duty Ratings**

Catalog Number	Description	Volts	Single Throw (Amperes)	Double Throw (Amperes)
DS200EK1	1NO-1NC	115	2.0	0.5
DS200EK1	1NO-1NC	230	0.5	0.2
DS200EK1	1NO-1NC	600	0.1	0.02
DS200EK2	2NO/2NC	115	1.0	0.2
DS200EK2	2NO/2NC	230	0.3	0.1
DS200EK2	2NO/2NC	600	0.1	—

Approximate Dimensions in Inches (mm)

**DS050MH****Myers Type Hubs**

NEMA 3R (400A and above)  
NEMA 4, 4X (stainless steel), 12

Catalog Number	Conduit Size
DS050MH	0.50 (12.7)
DS075MH	0.75 (19.1)
DS100MH	1.00 (25.4)
DS125MH	1.25 (31.8)
DS150MH	1.50 (38.1)
DS200MH	2.00 (50.8)
DS250MH	2.50 (63.5)
DS300MH	3.00 (76.2)
DS350MH	3.50 (88.9)
DS400MH	4.00 (101.6)
DS500MH	5.00 (127.0)

**DS075H1****Plate Type Hubs**

For NEMA 3R enclosures (up to 200A)

**Group 1**  
General-Duty, Heavy-Duty,  
Double-Throw Through 100A

Catalog Number	Conduit Size
DS075H1	0.75 (19.1)
DS100H1	1.00 (25.4)
DS125H1	1.25 (31.8)
DS150H1	1.50 (38.1)
DS200H1	2.00 (50.8)

**Group 2**  
General-Duty, Heavy-Duty,  
Double-Throw—200A

Catalog Number	Conduit Size
DS200H2	2.00 (50.8)
DS250H2	2.50 (63.5)
DS300H2	3.00 (76.2)
—	—
—	—

Catalog number **DS900AP** adapter kit permits installation of Group 1 hubs on 200A type general-duty, heavy-duty and double-throw switches.